

SERVICE MANUAL



P3150/P3250/P3150 Refresh/P3250 Refresh/P3251

Date	Revise Version	Description
2008.4.10	V1.0	Initial Issue
2008.5.28	V2.0	Add Marketing Spec in Chapter 1
2008.7.22	V3.0	Add P3150 Refresh/P3250 Refresh
2008.10.10	V4.0	Add Waveform Download in Ch5 modify Ch4, Ch6 and AppendixB
2010.02.26	V5.0	Add P3251

Copyright Feb.2010 All Rights Reserved P/N: 36.89K01G001

Prepared: *huhui*

Checked: *Joanna*

Approved: *Aliek*

Comparison List

PART	P3251	P3150	P3150 refresh	P3250	P3250 refresh
FAN	49.8FN01G001	49.89S01G001			
ENGINE	70.8GC07GR01	70.89Y22GR01			
PHOTO SENSOR BD	80.8GB04G001	80.88N04G001			
COLOR WHEEL	70.8GC08GR01	70.89Y21GR01			
DMD BD	80.8FN02G001	80.89S02G001			
DMD CHIP	48.8CQ01G003	48.87K01G001		48.87M01G001	
BALLAST	70.8GC09GR01	70.89Y27GR01			
SPEAKER	49.8GC01G001	49.89Y01G001			
MAIN BD	70.8GC10GR01	70.89Y23GR01	70.89Y33GR01	70.89Y29GR01	70.89Y33GR01
DAUGHTER BD	80.8GB06G001	NA			
FRONT COVER	70.8GC11GR01	70.89Y24GR01			
FFC CABLE	42.00300G001	42.89501G002			
KEYPAD BD	80.8GB03G001	80.89Y03G001			
TOP COVER	70.8GC12GR01	70.89Y25GR01		70.89Y30GR01	
BOTTOM COVER	70.8GC13GR01	70.89Y26GR01			
IR SENSOR BD	80.8GB05G001	80.89S05G001			

Preface

This manual is applied to P3150/P3250/P3150 refresh/P3250 refresh/P3251 projection system. The manual gives you a brief description of basic technical information to help in service and maintain the product.

Your customers will appreciate the quick response time when you immediately identify problems that occur with our products. We expect your customers will appreciate the service that you offer them.

This manual is for technicians and people who have an electronic background. Please send the product back to the distributor for repairing and do not attempt to do anything that is complex or is not mentioned in the troubleshooting.

Notice:

The information found in this manual is subject to change without prior notice. Any subsequent changes made to the data herein will be incorporated in future edition.

P3150/P3250/P3150 refresh/P3250 refresh/P3251 Service Manual

Copyright Feb.2010

All Rights Reserved

Manual Version 5.0

Table of Content

Chapter 1 Introduction

Highlight	1-1
Compatible Mode	1-4
Product Overview	1-6

Chapter 2 Disassembly Process

Equipment Needed & Product Overview	2-1
Disassemble Lamp Cover Module	2-2
Disassemble Lamp Module	2-3
Disassemble Top Cover Module	2-4
Disassemble Key Pad Board Module	2-5
Disassemble Zoom Ring Module	2-5
Disassemble Main Board Module	2-6
Disassemble Color Wheel Module	2-8
Disassemble Front Cover Module	2-9
Disassemble Ballast Module	2-10
Disassemble DC-DC Module	2-11
Disassemble Thermal Switch Module	2-12
Disassemble Lamp Blower and System Fan Module	2-13
Disassemble Lamp to Ballast Cable	2-14
Disassemble Engine Module	2-15
Disassemble DMD Board and DMD Ship	2-15
Disassemble Speaker Module	2-16
Disassemble Interrupt Switch Module	2-16
Disassemble IR Sensor Module	2-17
Rod Adjustment	2-18

Re-write Lamp Usage Hour	2-19
Assemble IR Sensor Module	2-20
Assemble Interrupt Switch Module	2-20
Assemble Speaker Module	2-21
Assemble DMD Board and DMD Chip Module	2-22
Assemble Engine Module	2-22
Assemble Lamp to Ballast Module	2-23
Assemble Lamp Blower and System Fan Module	2-24
Assemble Thermal Switch Module	2-25
Assemble DC-DC Module	2-26
Assemble Ballastl Module	2-27
Assemble Front Cover Module	2-28
Assemble Color Wheel Module	2-29
Assemble Main Board Module	2-30
Assemble Zoom Ring Module	2-31
Assemble Key Pad Board Module	2-32
Assemble Top Cover Module	2-33
Assemble Lamp Module	2-34
Assemble Lamp Cover Module	2-35

Chapter 3 Troubleshooting

LED Lighting Message	3-1
Main Procedure	3-3
Beep Sound	3-4

Chapter 4 Function Test & Alignment Procedure

Test Equipment Needed	4-1
Service Mode	4-1

OSD Reset	4-1
Test Condition	4-2
Test Inspection Procedure	4-4
PC Mode	4-4
Video Performance	4-7
Optical Performance Measure	4-9
SD Card /USB Test (only for P3251)	4-11
Other	4-12

Chapter 5 Firmware Upgrade

Section 1: System Firmware Upgrade	5-1
Equipment Needed	5-1
DLP Composer Lite Setup Procedure	5-2
USB Driver Upgrade Procedure	5-4
Firmware Upgrade Procedure	5-5
Section 2 : Waveform Download	5-9
Waveform Download (for refresh models)	5-9
Waveform Download (for P3251)	5-10
Section 3 : Multi-Media Firmware Upgrade(only for P3251)	5-11
Equipment Needed	5-11
USB Driver Upgrade Procedure	5-12
Multi-Media Firmware Upgrade Procedure	5-14

Chapter 6	EDID Upgrade	
	EDID Introduction	6-1
	Equipment Needed	6-2
	Setup Procedure	6-3
	EDID Key-In Procedure	6-3
	Setup Procedure (HDMI)	6-7
	Default Language Reset	6-9
Appendix A	P3150/P3250 Exploded Overview	I
Appendix B	Serial Number System Definition	I
	PCBA Code Definition	II

Introduction

1-1 Highlight

No	Item	Description
1	Dimensions (WxDxH)	- 209 x 74.2 x 172.2 mm (for P3150/P3250/P3150 Refresh/ P3250 Refresh) - 209 x 64 x 164mm (for P3251)
2	Weight	- 1.24 kg
3	Tilt Angle	- 7 degree with elevator mechanism
4	Keystone correction	- +/- 40 degree (80 degree)
5	DMD Chip	- TI DMD 0.55" 12° 2xLVDS Type-X SVGA Digital Mirror Device (for P3150/P3150 refresh) - TI DMD 0.55" 12° 2xLVDS Type-X XGA Digital Mirror Device (for P3250/P3250 refresh) - TI DMD 0.55" 12° 2xLVDS S450 XGA Digital Mirror Device (for P3251)
6	Number of active dots	- 800(H) x 600(V) (for P3150/P3150 refresh) - 1024(H) x 768(V) (for P3250/3250 refresh/P3251)
7	Power Supply	- Universal AC 100 -240 V ~ 50-60 Hz with PFC input - Variance FAN speed control (Depends on temperature variant)
8	Terminal	For all models: - HDMI * 1: One HDMI connector for HDMI-Video/audio and HDMI-Graphic Signal. (HDMI v1.3 for P3251, HDMI v1.1 for P3250/P3150) - VGA input (D-SUB X 1) - Video input (RCA jack Type X 1, Mini DIN 4-pin S-video X 1) - Audio input (Phone jack Type X 1) - USB (Type-B X 1) Only for P3251: - SD * 1 - USB (Type-A* 1)
9	Lamp	- 165 Watt for OSRAM E17.6 Lamp @ normal operation
10	Projection lens	- F# 2.41 ~2.55, f = 21.79~23.99 mm, 1.10X Mechanical Zoom Lens
11	Projection Image Size	- Adjustable from 22.9" to 302.8" (Diagonal) (for P3150/P3250/ P3150 Refresh/P3250 Refresh) - Adjustable from 27.5" to 303" (for P3251)

No	Item	Description
12	Throw Distance	- 1.0m – 12m
13	Throw Ratio	- 1.95 – 2.15:1 @ 60"
14	Input signal spec	<p>- Video Signal RGB (PC)</p> <ul style="list-style-type: none"> • Analog RGB 0.7Vp-p, 75 ohm, Separate TTL H,V Sync • Analog RGB 1Vp-p, 75 ohm, Sync. On Green signal • Analog RGB 0.7Vp-p, 75 ohm, Composite TTL Sync. <p>- Video</p> <ul style="list-style-type: none"> • Composite video 1Vp-p,75 ohm • S-video Luminance 0.714Vp-p, 75 ohm • Chrominance 0.286Vp-p, 75 ohm • Component Video 1Vp-p, 75 ohm <p>For P3150/P3250/P3150 Refresh/P3250 Refresh:</p> <ul style="list-style-type: none"> - Hsync Frequency 31.5 k ~ 100 kHz - Vsync Frequency 50 ~ 85 Hz <p>For P3251:</p> <ul style="list-style-type: none"> - Hsync Frequency 30 ~ 100 kHz - Vsync Frequency 50 ~ 120 Hz
15	Video Compatibility	<p>- Standards :</p> <ul style="list-style-type: none"> • NTSC (3.58/4.43) • PAL (B/D/G/H/I/M/N) • SECAM (B/D/G/K/K1/L) • HDTV - 480p, 576p, 720p, 1080i (for P3150/3150 refresh) • HDTV - 480p, 576p, 720p, 1080p (for P3250/P3250 refresh) • HDTV (480i,576i 480p, 576p, 720p, 1080i, 1080p) (for P3251)
16	Brightness	<p>P3150/P3250/P3150 refresh/P3250 refresh</p> <p>- Engineering Spec:</p> <ul style="list-style-type: none"> • 1800 ANSI Lumens (Typical; Full power mode) • 1600 ANSI Lumens (Minimum; Full power mode) <p>- Marketing Spec:</p> <ul style="list-style-type: none"> • 2000 ANSI Lumens <p>P3251 Engineering Spec:</p> <p>- Engineering Spec:</p> <ul style="list-style-type: none"> • 1890 ANSI Lumens (Typical) • 1680 ANSI Lumens (Minimum) <p>- Marketing Spec:</p> <ul style="list-style-type: none"> • 2100 ANSI Lumens

No	Item	Description
17	Contrast	P3150/P3250/P3150 refresh/P3250 refresh : - Engineering Spec: <ul style="list-style-type: none"> ● 1400 : 1 Full White and Black (Minimum; Full power mode) ● 1800 : 1 Full White and Black (Typical; Full power mode) - Marketing Spec: <ul style="list-style-type: none"> ● 2000 :1 Full White and Black P3251 : - Engineering Spec: <ul style="list-style-type: none"> ● 2100 : 1 Full White and Black (Minimum; Full power mode) ● 3300 : 1 Full White and Black (Typical; Full power mode) - Marketing Spec: <ul style="list-style-type: none"> ● 3700 :1 Full White and Black
18	Uniformity	Engineering Spec: - 65% Japan standard (Minimum; Full power mode) - 80% Japan standard (Typical; Full power mode) Marketing Spec: - 85% Japan standard
19	Color Wheel	<ul style="list-style-type: none"> ● 6 segments (R90Y28G90C28W42B80) (for P3150/P3250/P3150 refresh/P3250 refresh) ● 6 segments (R81Y41G84C31W52B71) (for P3251) - 7200rpm @ 2x - 9000rpm @ 3x, PAL 50Hz
20	Operation temperature	- 5°C -- 35°C
21	Storage temperature	- -20°C -- 60°C
22	Maximum Humidity	- Operating: 5°C -- 35°C, 80%RH (Max.), non-condensing - Storage: -20°C -- 60°C, 80%RH (Max.), non-condensing
23	Lamp life	P3150/P3250/P3150 refresh/P3250 refresh : - 3000 hours min, 50% survival rate (Full power Mode) - 4000 hours min, 50% survival rate (Eco power Mode) P3251 : - 3500 hours, 50% survival rate (Full power Mode) - 5000 hours, 50% survival rate (Eco power Mode)
24	System controller	- TI DDP2230 (for P3150/P3250/P3150 refresh/P3250 refresh) - TI DDP2431 (for P3251)

1-2 Compatible Mode

A. Analog (for P3150/P3250/P3150 Refresh/P3250 Refresh)

Compatibility	Resolution	V-Sync [Hz]	H-Sync [KHz]
VGA	640x480	60	31.50
	640x480	72	37.90
	640x480	75	37.50
	720x400	70	31.50
SVGA	800x600	56	35.20
	800x600	60	37.90
	800x600	72	48.10
	800x600	75	46.90
	832x624	75	49.73
XGA	1024x768	60	48.40
	1024x768	70	56.50
	1024x768	75	60.00
SXGA	1152x864	70	63.80
	1280X1024	60	63.98
QuadVGA	1280x960	60	59.70
	1280x960	75	75.23
SXGA+	1400x1050	60	65.32
WXGA	1280x800	60	49.702
	1360x768	60	47.72
	1440x900	60	55.935
	1680x1050	60	65.290
UXGA	1600x1200	60	75.00
Power Mac G4	640x480	66.6(67)	34.93
	800x600	60	37.90
	1024x768	60	48.40
	1152x870	75	68.68
	1280x1024	60	63.98
PowerBook G4	640x480	60	31.35
	640x480	66.6(67)	34.93
	800x600	60	37.90
	1024x768	60	48.40
	1152x870	75	68.98
	1280x1024	60	63.98
i Mac DV (G3)	1024X768	75	60.00

B. Digital (for P3150/P3250/P3150 Refresh/P3250 Refresh)

Compatibility	Resolution	V-Sync [Hz]	H-Sync [KHz]
VGA	640x480	60	31.50
	640x480	72	37.90
	640x480	75	37.50
	720x400	70	31.50
SVGA	800x600	56	35.20
	800x600	60	37.90
	800x600	72	48.10
	800x600	75	46.90
	832x624	75	49.73
XGA	1024x768	60	48.40
	1024x768	70	56.50
	1024x768	75	60.00
SXGA	1152x864	70	63.80
	1280X1024	60	63.98
QuadVGA	1280x960	60	59.70
	1280x960	75	75.23
SXGA+	1400x1050	60	65.32
WXGA	1280x800	60	49.702
	1360x768	60	47.72
	1440x900	60	55.935
	1680x1050	60	65.290
UXGA	1600x1200	60	75.00
Power Mac G4	640x480	66.6(67)	34.93
	800x600	60	37.90
	1024x768	60	48.40
	1152x870	75	68.68
	1280x1024	60	63.98
PowerBook G4	640x480	60	31.35
	640x480	66.6(67)	34.93
	800x600	60	37.90
	1024x768	60	48.40
	1152x870	75	68.68
	1280x1024	60	63.98
i Mac DV (G3)	1024X768	75	60.00

1-3 Product Overview

Projector Outlook (P3150)

Front /Upper side

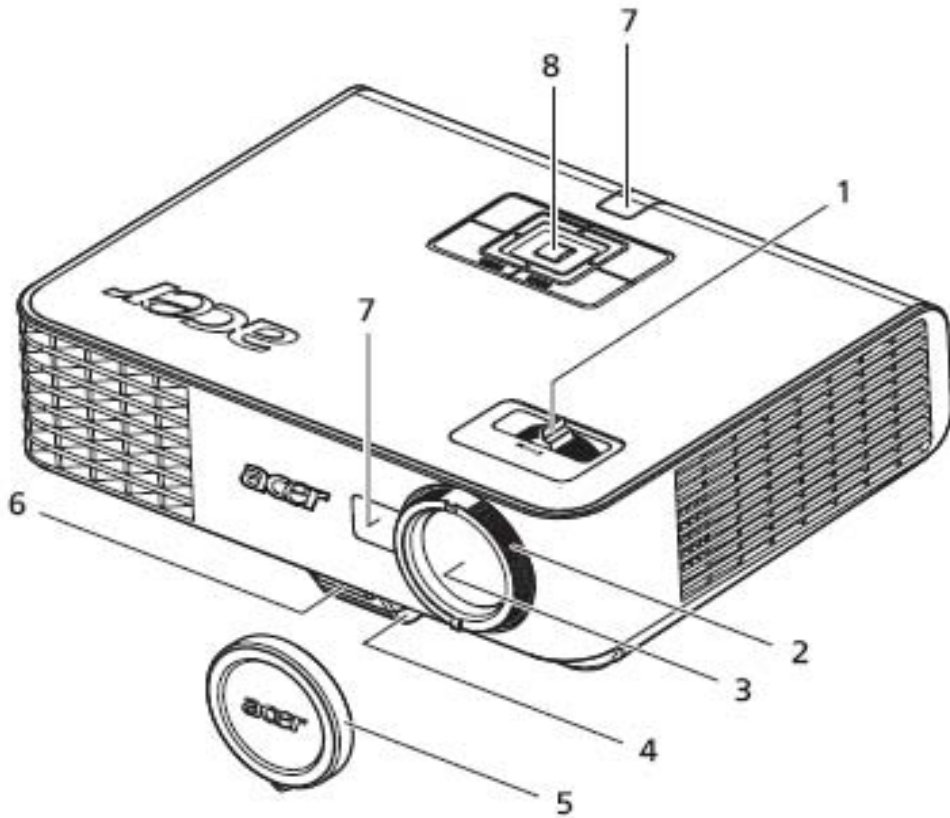

Item	Description	Item	Description
1	Zoom Lever	6	Elevator button
2	Focus ring	7	Remote control receivers
3	Zoom lens	8	Control panel
4	Elevator foot		
5	Lens cap		

Rear side (for P3150/P3250/P3150 Refresh/P3250 Refresh)

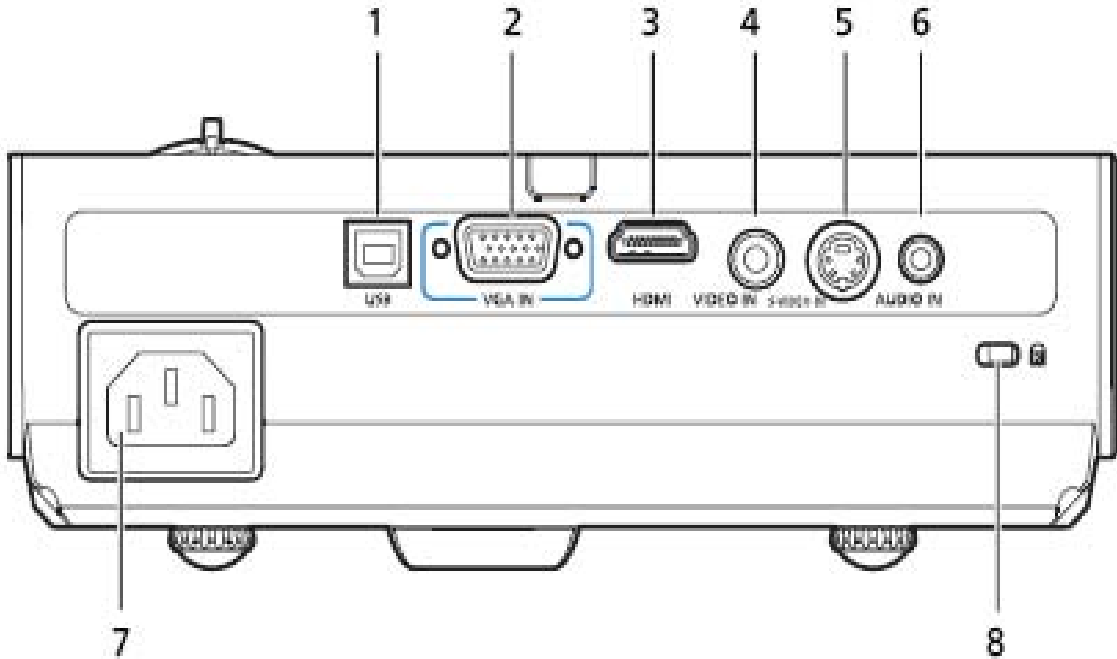

Item	Description	Item	Description
1	USB connector	5	S-Video input connector
2	PC analog signal/HDTV/component video input connector	6	Audio input connector
3	HDMI connector	7	Power socket
4	Composite video input connector	8	KensingtonTM lock port



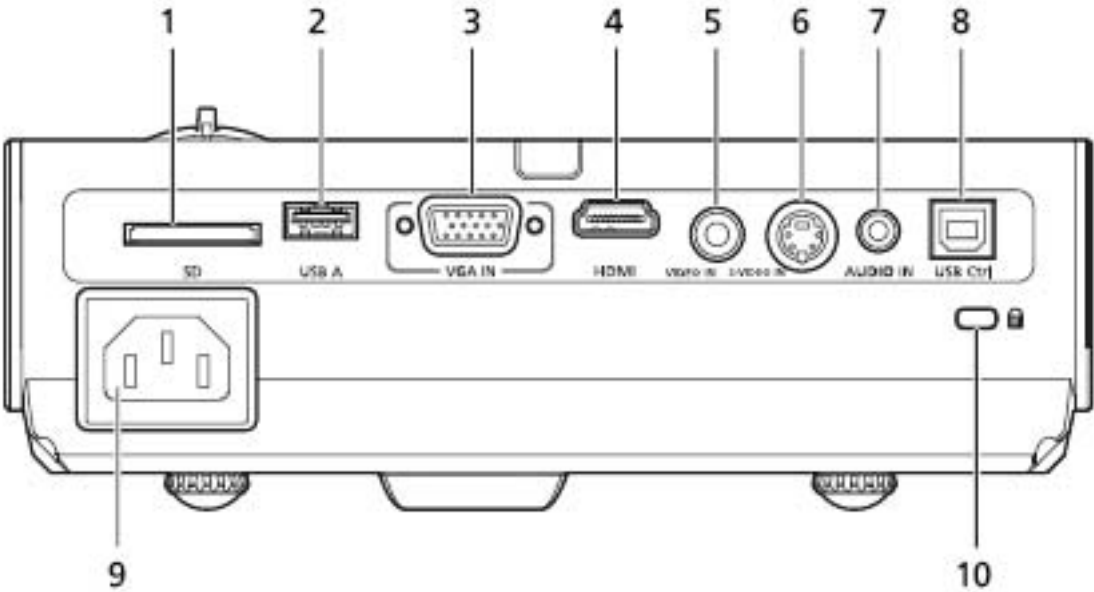

Rear side (for P3251)

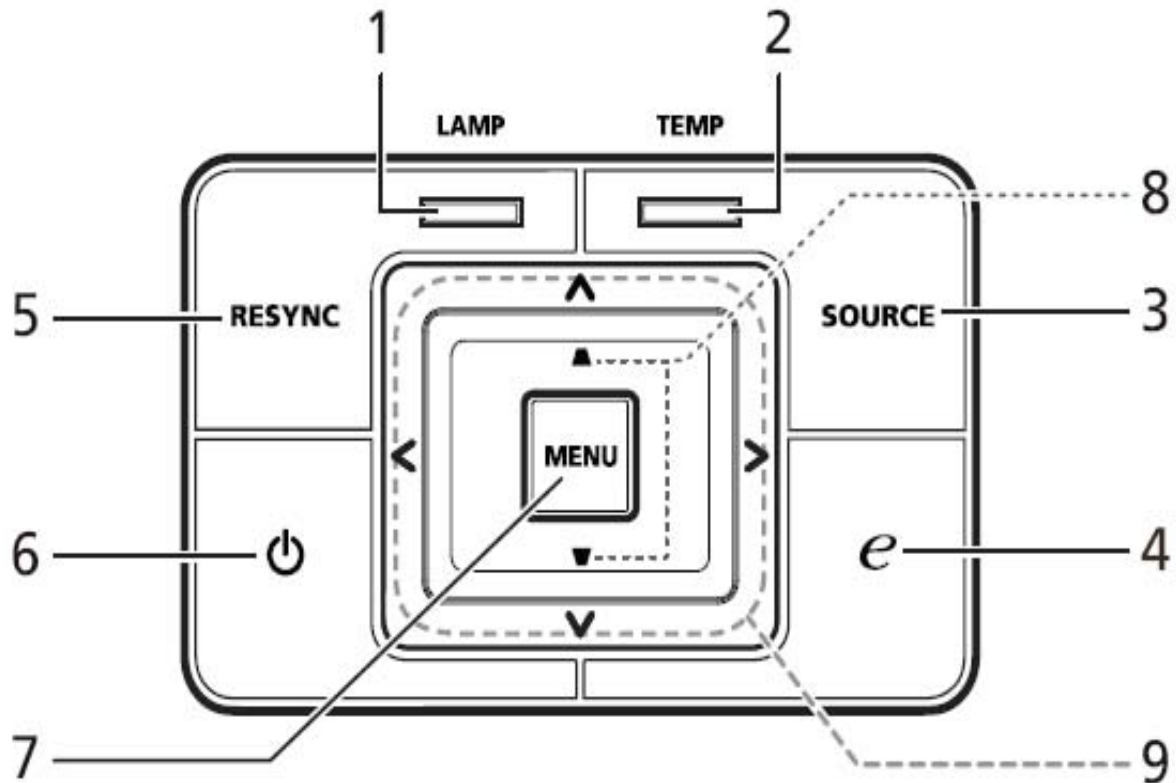

Item	Description	Item	Description
1	SD Card reader	6	S-Video input connector
2	USB A connector	7	Audio input connector
3	PC analog signal/HDTV/component video input connector	8	USB control connector
4	HDMI connector	9	Power socket
5	Composite video input connector	10	KensingtonTM lock port





Control Panel

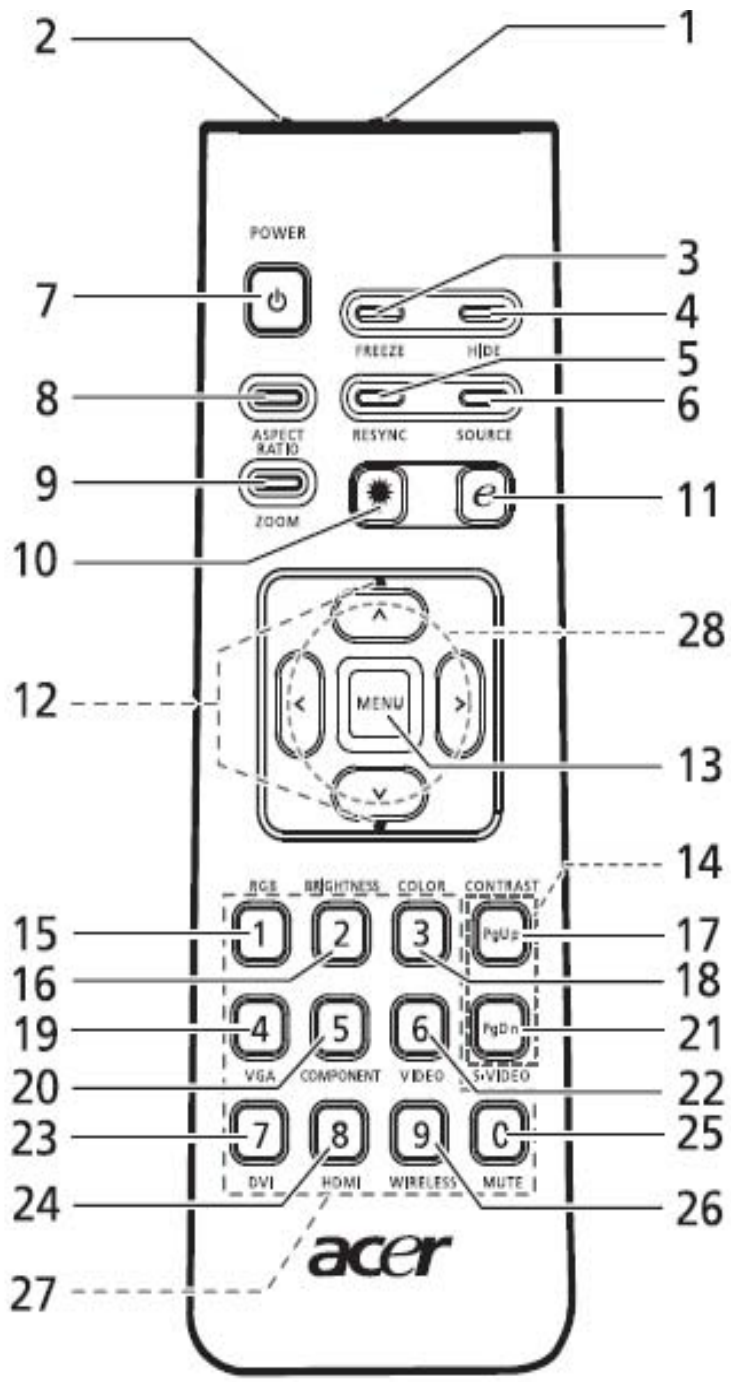

Item	Function	Description
1	LAMP	Lamp Indicator LED
2	TEMP	Temp Indicator LED
3	SOURCE	Press "SOURCE" to choose RGB, S-Video, Composite and HDMI™ sources.
4	Empowering key	Unique Acer functions: eOpening, eView, eTimer.
5	RESYNC	Automatically synchronizes the projector to the input source
6	POWER	Power/Standby/Power Indicator LED. See the contents in "Turning the Projector On/Off" section.
7	MENU	<ul style="list-style-type: none"> • Press "MENU" to launch the Onscreen display (OSD) menu, back to the previous step for the OSD menu operation or exit the OSD menu. • Confirm your selection of items.
8	Keystone	Adjusts the image to compensate for distortion caused by tilting the projector (± 40 degrees).
9	Four directional select keys	Use to     select items or make adjustments to your selection.

Remote Control Layout (for P3150/P3250/P3150 Refresh/P3250 Refresh)









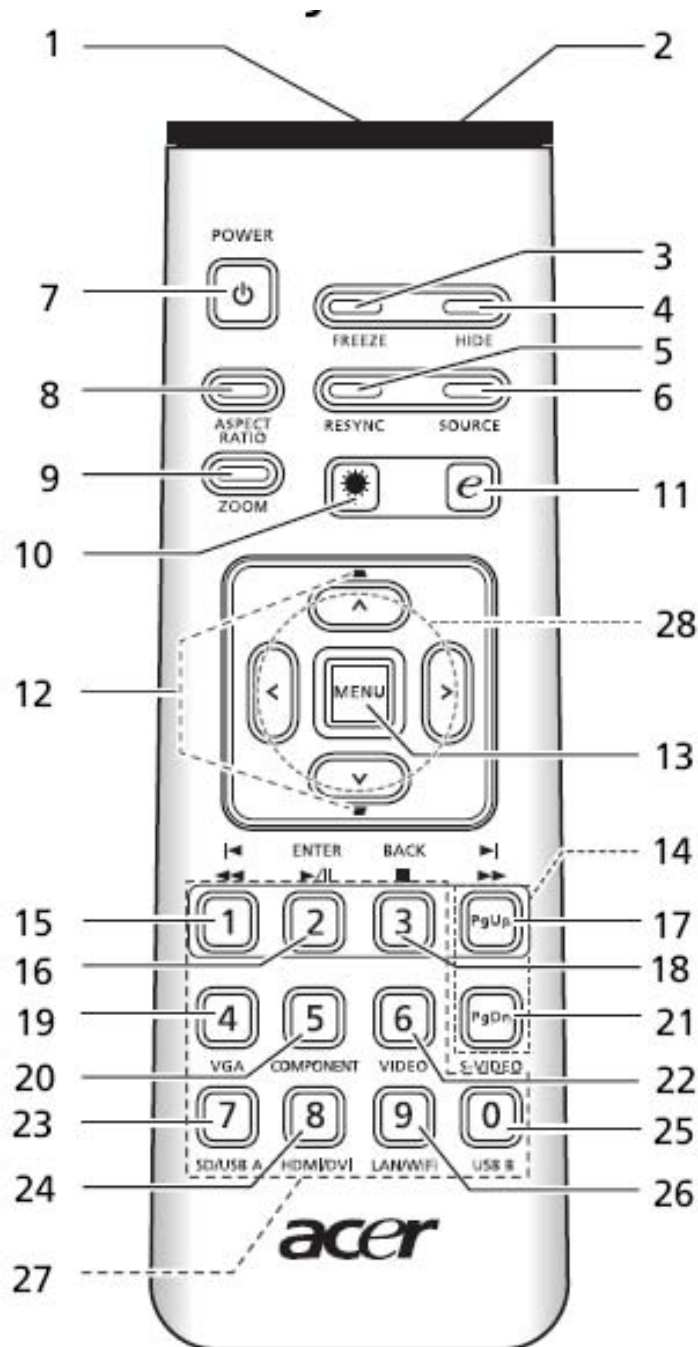



Item	Icon	Function	Description
1		Infrared transmitter	Sends signals to the projector.
2		Laser pointer	Aim the remote at the viewing screen
3		FREEZE	To pause the screen image.
4		HIDE	Momentarily turns off the video. Press "HIDE" to hide the image, press again to display the image.
5		RESYNC	Automatically synchronizes the projector to the input source.
6		SOURCE	Press "SOURCE" to choose from RGB, Component-p, Component-i, S-Video, Composite, Video and HDTV sources.
7		POWER	Refer to the "Turning the Projector On/Off" section.
8		ASPECT RATIO	To choose the desired aspect ratio (Auto/4:3/16:9).
9		ZOOM	Zooms the projector display in or out..
10		Laser button	Aim the remote at the viewing screen, press and hold this button to activate the laser pointer. This function is not supported in Japanese market.
11		Empowering key	Unique Acer functions: eOpening, eView, eTimer Management
12		KEYSTONE	Adjusts the image to compensate for distortion caused by tilting the projector (± 40 degrees).
13		MENU	<ul style="list-style-type: none"> Press "MENU" to launch the Onscreen display (OSD) menu, back to the previous step for the OSD menu operation or exit the OSD menu. Confirm your selection of items.
14		PAGE	For computer mode only. Use this button to select the next or previous page. This function is only available when connected to a computer via a USB cable.
15		RGB	Press "RGB" for true-color optimization.
16		BRIGHTNESS	Press "BRIGHTNESS" to adjust the brightness of the image.
17		CONTRAST	Use the "CONTRAST" option to control the difference between the lightest and darkest parts of the picture.
18		COLOR	Press "COLOR" to adjust the color temperature of image.
19		VGA	Press "VGA" to change source to the VGA connector. This connector supports analog RGB, YPbPr (480p/576p/720p/1080i), YCbCr (480i/576i) and RGBsync.
20		COMPONENT	Press "COMPONENT" to change source to Component video. This connection supports YPbPr (480p/576p/720p/1080i) and YCbCr (480i/576i).
21		S-VIDEO	To change source to S-Video.
22		VIDEO	To change source to COMPOSITE VIDEO.
23		DVI	No DVI function.
24		HDMI™	To change source to HDMI™.
25		MUTE	To turn on/off the volume.

Item	Icon	Function	Description
26		WIRELESS	Press "WIRELESS" to display the image which is wirelessly transmitted from the PC to the projector via the "Acer eProjection Management" utility. (for wireless model)
27		KeyPad 0~9	Press "0~9" to input a password in the "Security settings".
28		Four directional select keys	Use up, down, left, right buttons to select items or make adjustments to your selection.

Remote Control Layout (for P3251)



Item	Icon	Function	Description
1		Infrared transmitter	Sends signals to the projector.
2#		Laser pointer	Aim the remote at the viewing screen
3		FREEZE	To pause the screen image.
4		HIDE	Momentarily turns off the video. Press "HIDE" to hide the image, press again to display the image.
5		RESYNC	Automatically synchronizes the projector to the input source.
6		SOURCE	Press "SOURCE" to choose from RGB, Component-p, Component-i, S-Video, Composite, Video and HDTV sources.
7		POWER	Refer to the "Turning the Projector On/Off" section.
8		ASPECT RATIO	To choose the desired aspect ratio (Auto/4:3/16:9).
9		ZOOM	Zooms the projector display in or out..
10#		Laser button	Aim the remote at the viewing screen, press and hold this button to activate the laser pointer. This function is not supported in Japanese market.
11		Empowering key	Unique Acer functions: eOpening, eView, eTimer Management
12		KEYSTONE	Adjusts the image to compensate for distortion caused by tilting the projector (± 40 degrees).
13		MENU	<ul style="list-style-type: none"> Press "MENU" to launch the Onscreen display (OSD) menu, back to the previous step for the OSD menu operation or exit the OSD menu. Confirm your selection of items.
14		PAGE	For computer mode only. Use this button to select the next or previous page. This function is only available when connected to a computer via a USB cable.
15		Pre./Rewind	Press "Pre./Rewind" to go to previous index or press continuously to rewind the playing media file.
16		Enter/Play/Pause	Press "Enter/Play/Pause" to play/pause media file.
17		Next/Fastforward	Press "Next/Fast-forward" once to go to next index or press continuously to fast-forward the playing media file.
18		Back/Stop	Press "Back/Stop" to stop playing media file or go back to upper data folder.
19		VGA	Press "VGA" to change source to the VGA connector. This connector supports analog RGB, YPbPr (480p/576p/720p/1080i), YCbCr (480i/576i) and RGBsync.
20		COMPONENT	No COMPONENT function.
21		S-VIDEO	Press "S-VIDEO" to change source to S-Video.
22		VIDEO	Press "VIDEO" to change source to composite video.
23		SD/USB A	Press "SD/USB A" to toggle between SD and USB A sources. This projector supports various file formats of photo/audio/video.

Item	Icon	Function	Description
24 *		HDMI™/DVI	Press “HDMI™/DVI” to change source to HDMI™.
25		USB B	No USB B function.
26		LAN/WiFi	No LAN/WiFi function.
27		KeyPad 0~9	Press “0~9” to input a password in the “Security settings”.
28		Four directional select keys	Use up, down, left, right buttons to select items or make adjustments to your selection.



Note: “#” Japan area is not supported.
 “*” No DVI function



Connecting the Projector

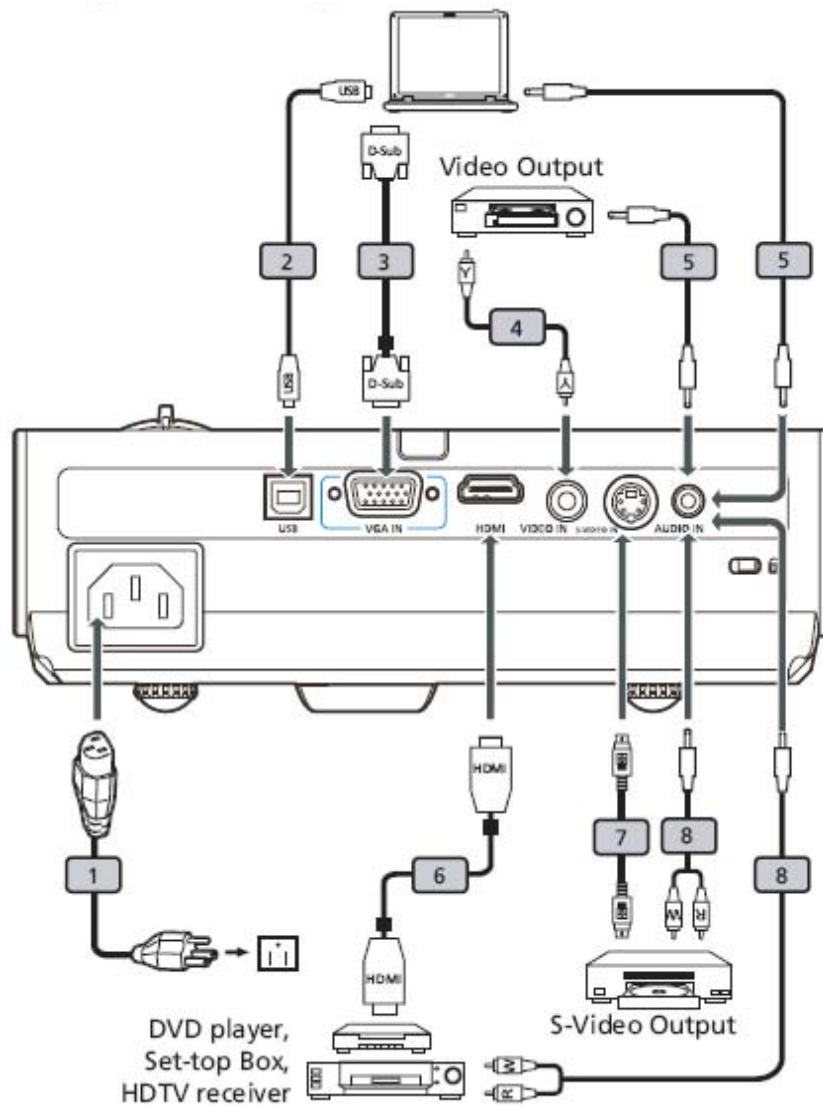

Item	Description	Item	Description
1	Power cord	5	Audio cable Jack/Jack
2	USB cable	6	HDMI cable
3	VGA cable	7	S-Video cable
4	Composite video cable	8	Audio cable Jack/RCA



Note: To ensure the projector works well with your computer, please make sure the timing of the display mode is compatible with the projector.

System Block Diagram

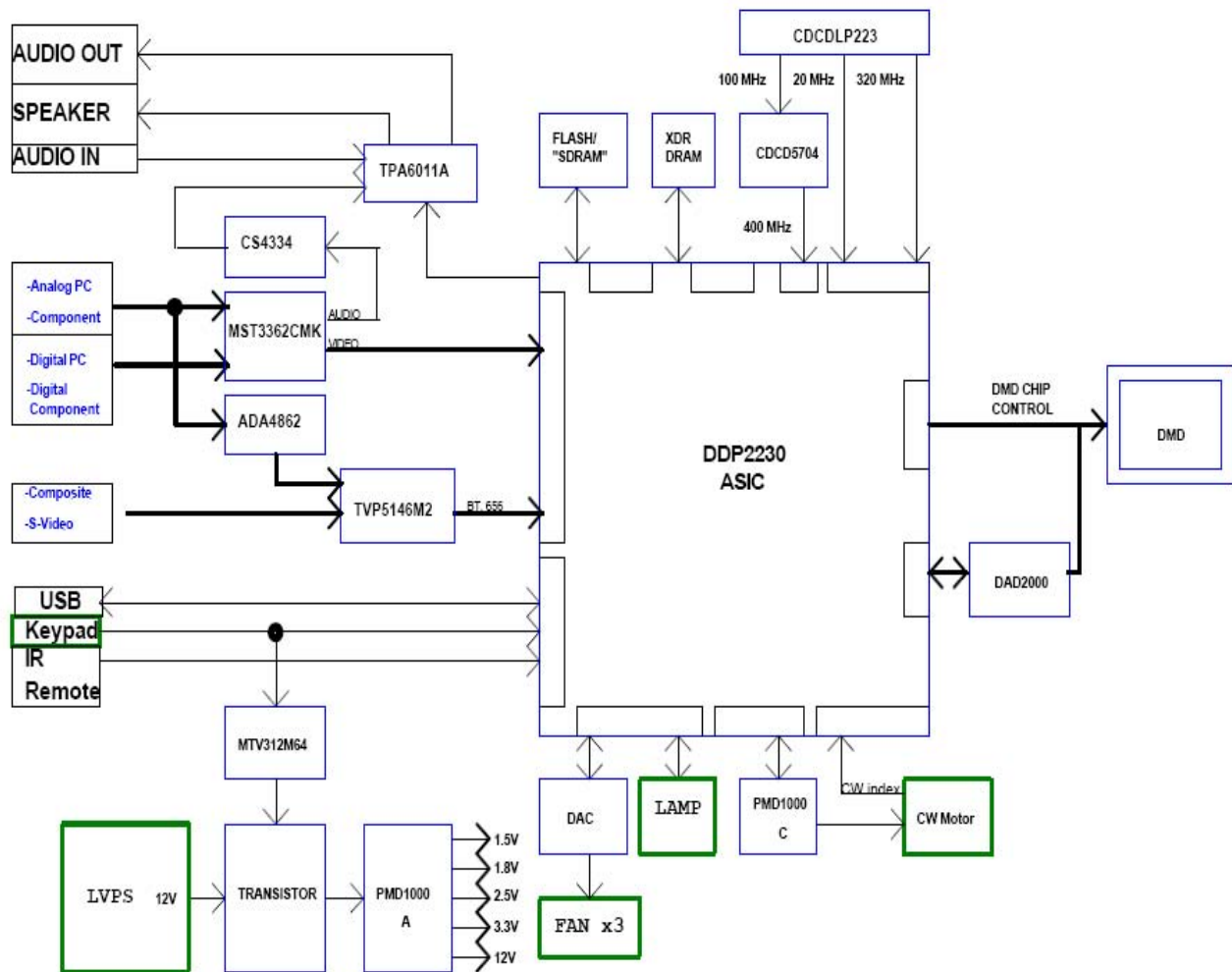

Bottom Cover Dimension

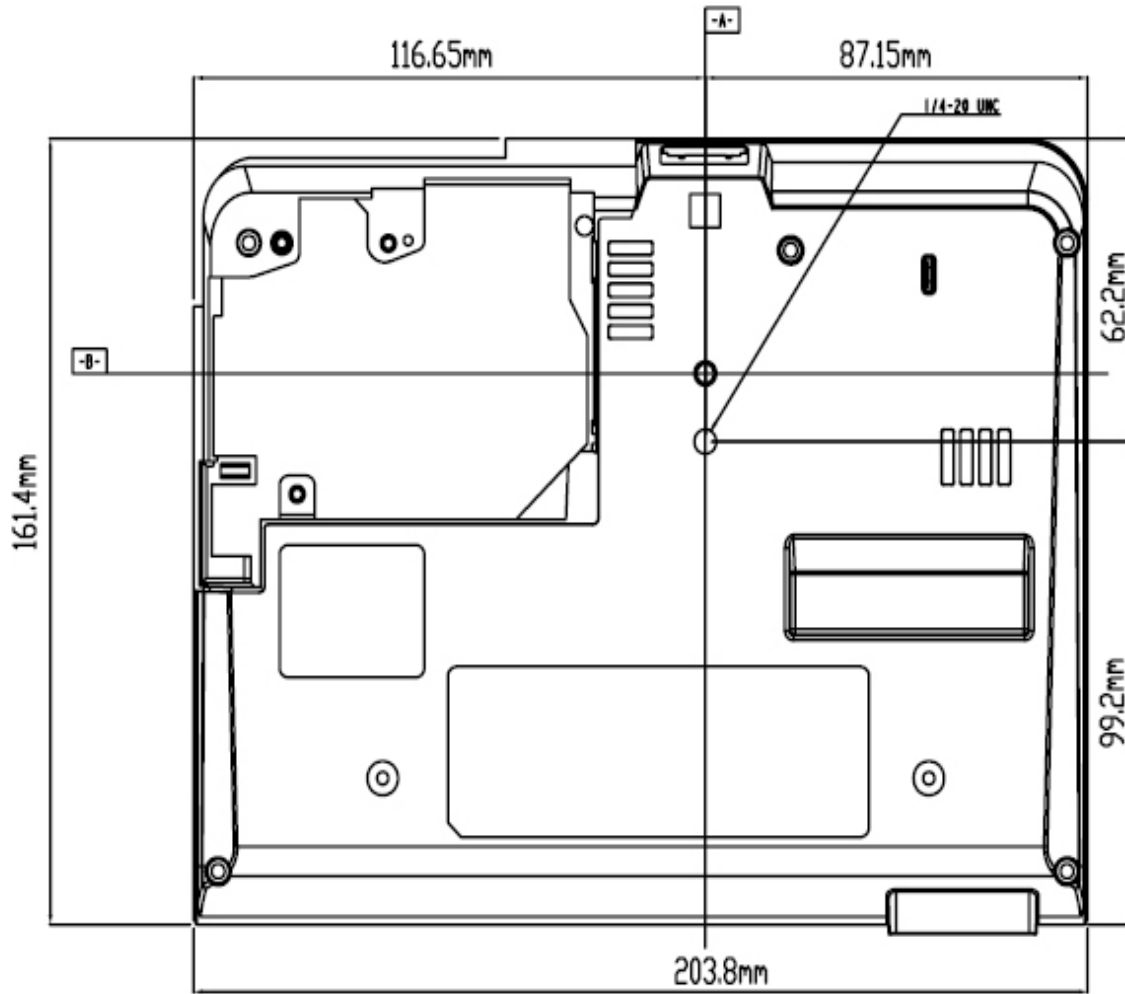

Disassembly & Assembly Process

2-1 Equipment Needed & Product Overview

1. Screw Bit (+) :107
2. Hex Sleeves 5mm
3. Long Nose Nipper
4. Screw Bit (+) :102
5. Hex Sleeves 7mm
6. Tweezers
7. P3150/P3250/P3150 refresh/P3250 refresh/P3251 unit

** Before you start: This process is protective level II. Operators should wear electrostatic chains.*

** Note: 1. If you need to replace the main board, you have to get into service mode and record the lamp usage hour. please refer to section 2-21.*

2. The disassembly and assembly process for P3150/P3250/P3150 refresh/P3250 refresh/P3251 is the same. Here, we take P3250 as an example.



2-2 Disassemble Lamp Cover Module

1. Turn over the projector
2. Unscrew 2 screws (as red circle)
3. Disassemble the Lamp Cover Module



2-3 Disassemble Lamp Module

1. Unscrew 2 screws (as red circle)
2. Disassemble Lamp Module



2-4 Disassemble Top Cover Module

1. Unscrew 5 screws (as red circle)
2. Unscrew 2 Hex screws (as yellow circle)
3. Unplug 1 FPC cable (as red square)
4. Disassemble Top cover



2-5 Disassemble Key Pad Board Module

1. Unscrew 4 screws (as red circle)
2. Separate Key Pad Button and Key Pad Board



2-6 Disassemble Zoom Ring Module

1. Unscrew 3 screws (as yellow circle)
2. Disassemble Zoom Ring Module
3. Release 2 tenons to outward (as red square)
4. Separate Zoom Ring and Zoom Ring Holder

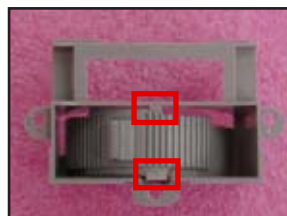

2-7 Disassemble Main Board Module

1. Tear off 2 Mylars (as red square)
2. Unplug 5 connectors (as green square)
3. Push Main Board Module (as red arrow) to unplug 1 connector (as yellow square)
4. Unplug 6 connectors (as orange square)

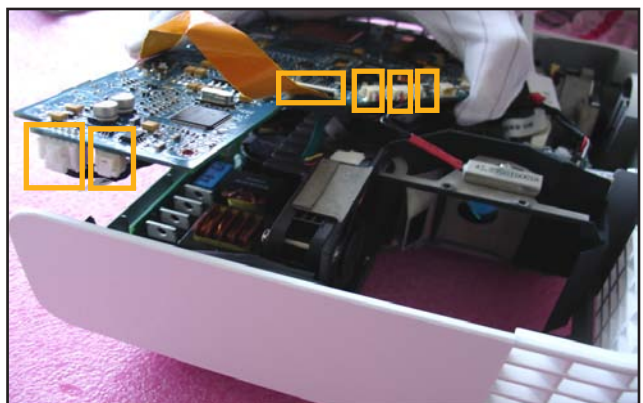
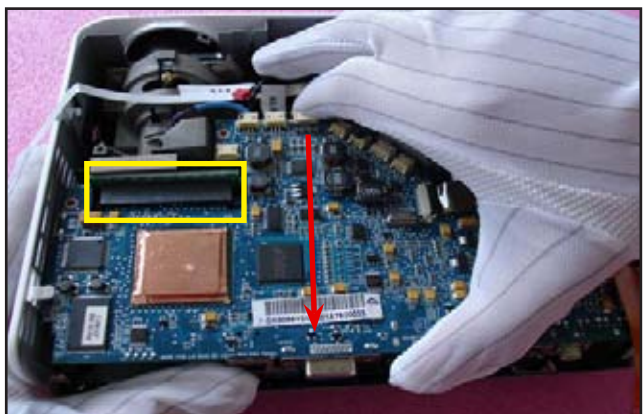
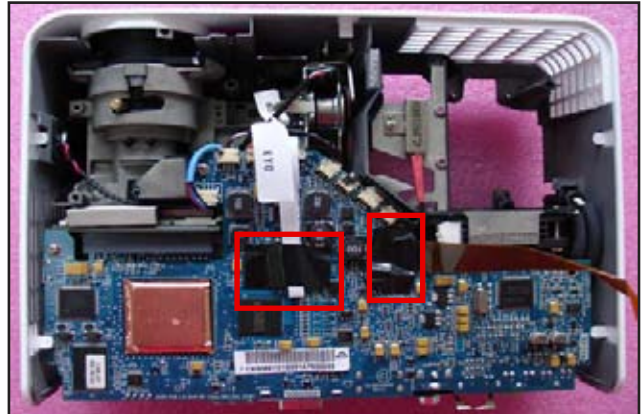

5. Disassemble Main Board Module

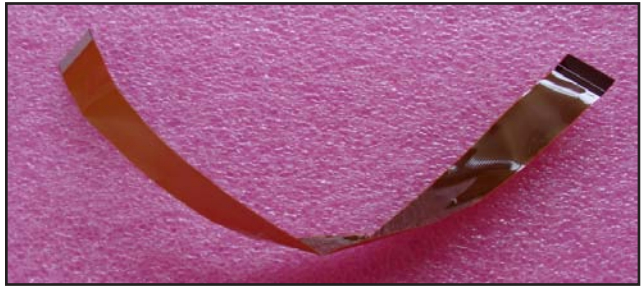

6. Unscrew 2 screws(as red circle) to disassemble the Daughter Board. (only for P3251)

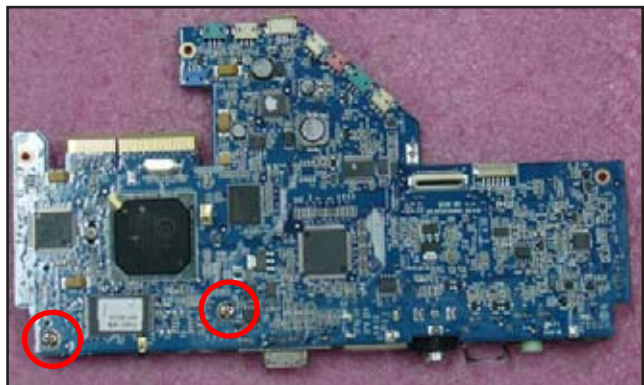

2-8 Disassemble Color Wheel Module

1. Unscrew 2 screws (as red circle)
2. Disassemble Color Wheel Module
3. Unscrew 1 screw (as yellow circle)
4. Disassemble Photo Sensor Board

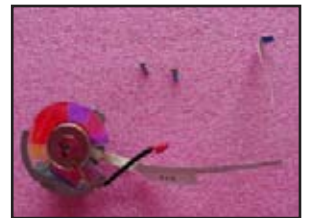
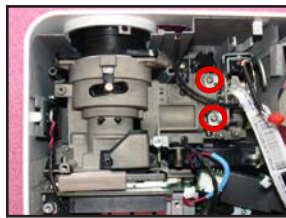
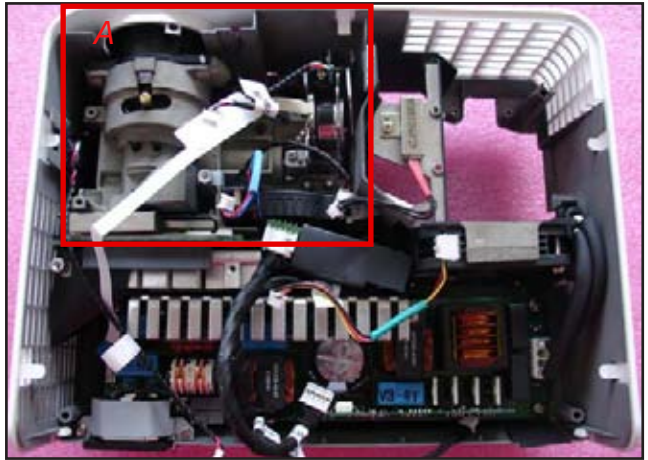

A

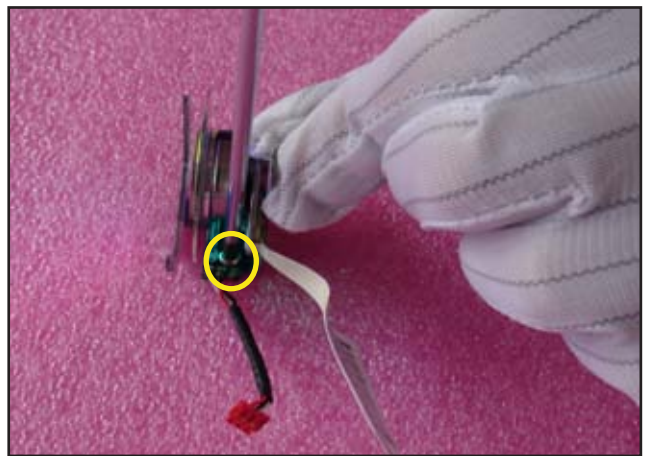

2-9 Disassemble Front Cover Module

1. Release 6 tenons (as red circle)
2. Push the front cover forward to disassemble front cover module

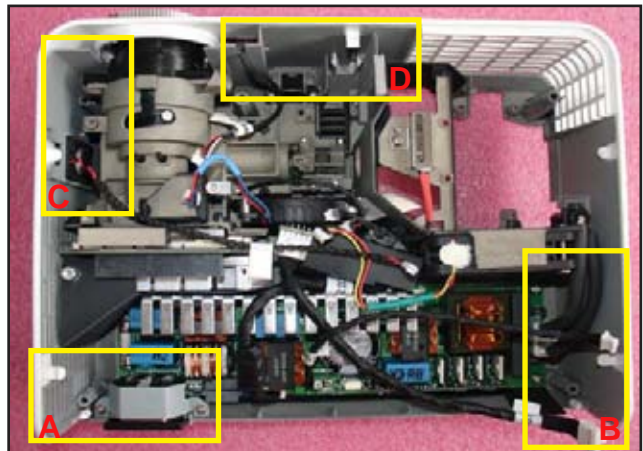

A



B



C



D



2-10 Disassemble Ballast Module

1. Unplug 2 cables (as red square)
2. Unscrew 3 screws (as red circle)
3. Disassemble AC Inlet Bracket
4. Unscrew 3 screws (as yellow circle)
5. Disassemble Ballast Module
6. Tear off 1 Mylar

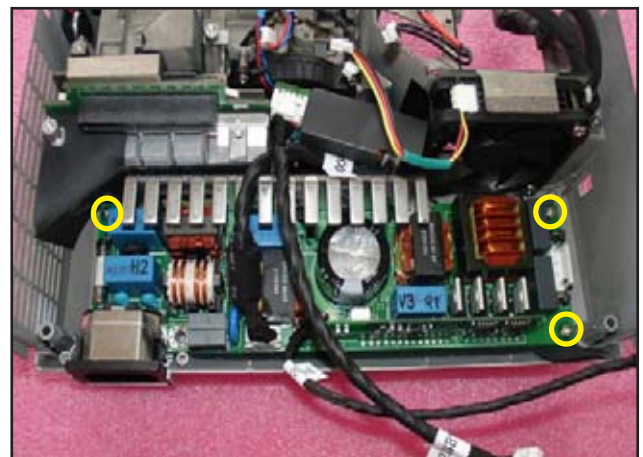
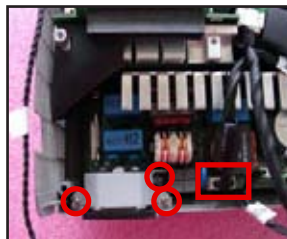
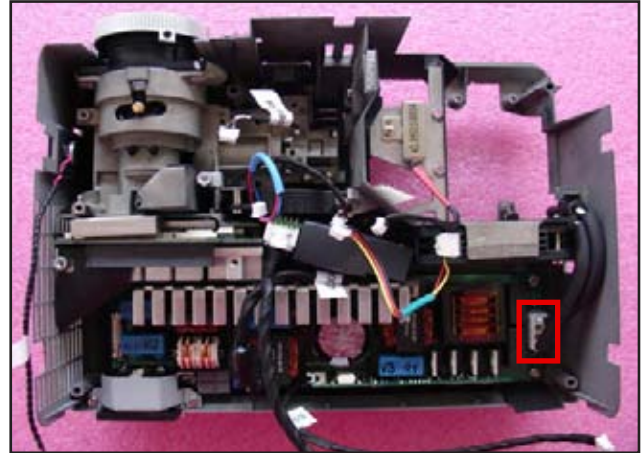

2-11 Disassemble DC-DC Module

1. Unscrew 1 screw (as red circle)
2. Disassemble DC-DC Module
3. Unplug 2 cables (as red square)

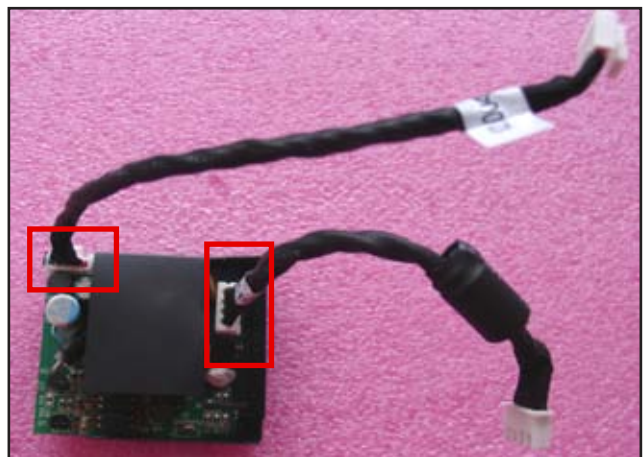
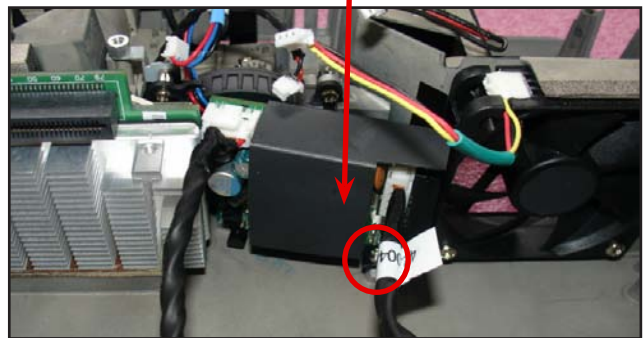
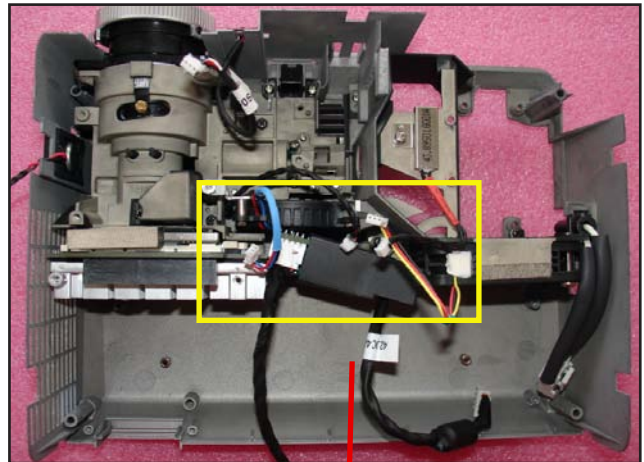

2-12 Disassemble Thermal Switch Module

- 1. Unscrew 1 screw (as red circle)
- 2. Disassemble Thermal Switch

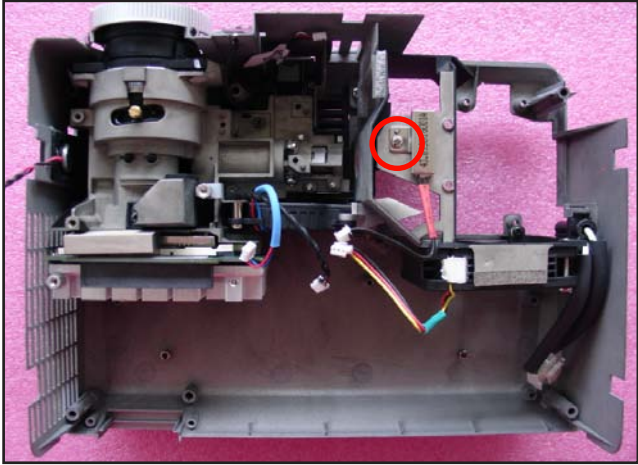

2-13 Disassemble Lamp Blower Module and System Fan Module

1. Unscrew 4 screws (as red circle)
2. Disassemble Lamp Blower Module and System Fan Module
3. Unscrew 3 screws (as yellow circle)
4. Separate Lamp Blower , Lamp Blower Duct and Lamp Blower Holder
5. Tear off 1 mylar (as red square)
6. Unscrew 3 screws (as green circle)
7. Separate System Fan and Lamp Housing

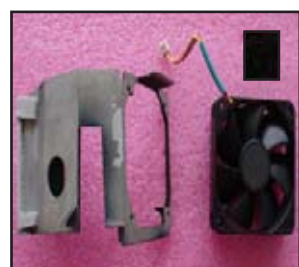
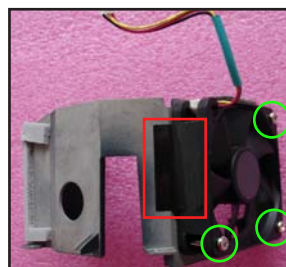
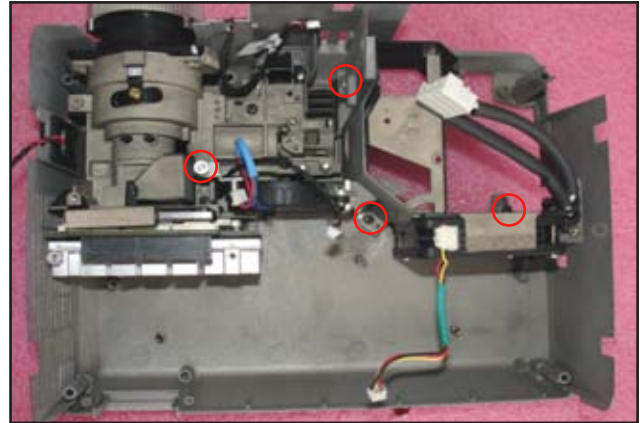

2-14 Disassemble Lamp to Ballast Cable

1. Unscrew 1 screw (as red circle)
2. Unplug Lamp to Ballast Cable

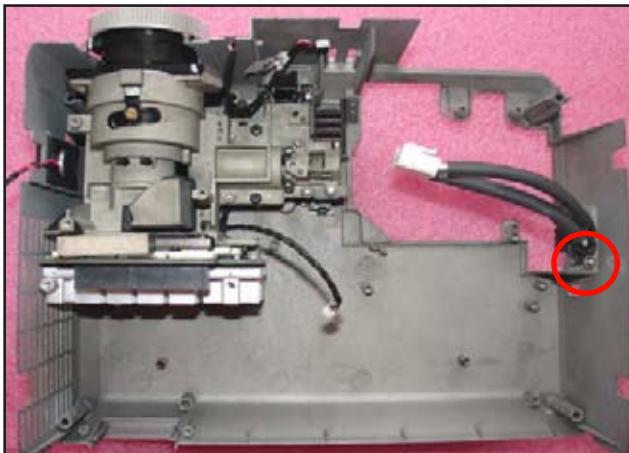

2-15 Disassemble Engine Module

1. Unscrew 4 screws (as red circle)
2. Disassemble Engine Module
3. Unscrew 3 screws (as yellow circle)
4. Disassemble Focus Ring

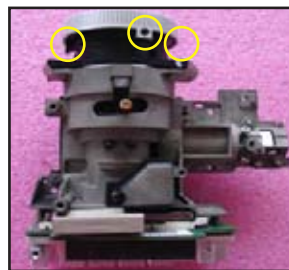
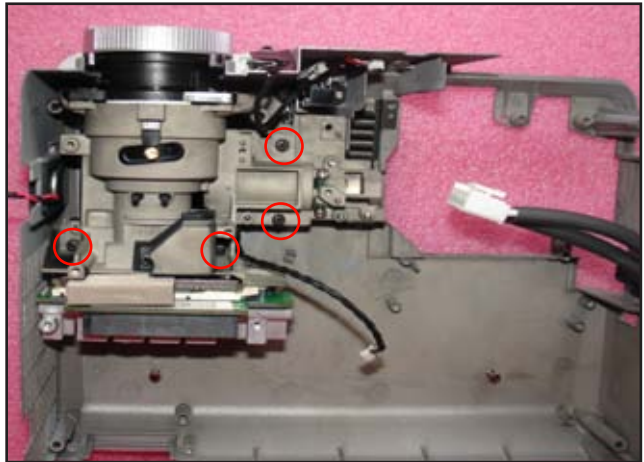

2-16 Disassemble DMD Board and DMD Chip

1. Unscrew 2 screws (as blue circle)
2. Disassemble Heat sink ,DMD Mask and DMD Rubber
3. Rotate DMD Chip Lock counterclockwise (as red arrow)
4. Separate DMD Board and DMD Chip

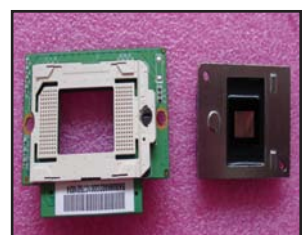
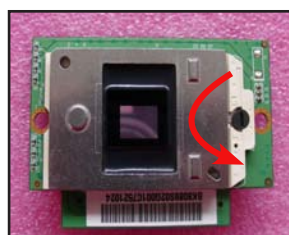
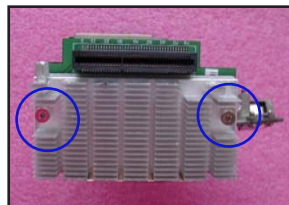

2-17 Disassemble Speaker Module

1. Disassemble Speaker Module
2. Separate Speaker and Rubber

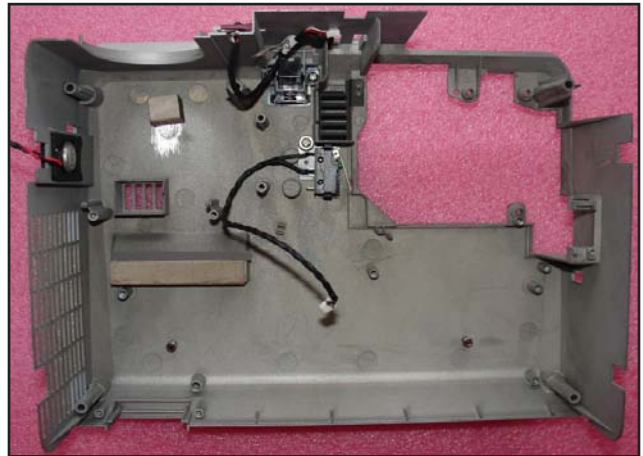

2-18 Disassemble Interrupt Switch Module

1. Unscrew 1 screw (as red circle)
2. Release 2 tenons (as yellow circle)
3. Separate Interrupt Switch and Interrupt Switch Holder

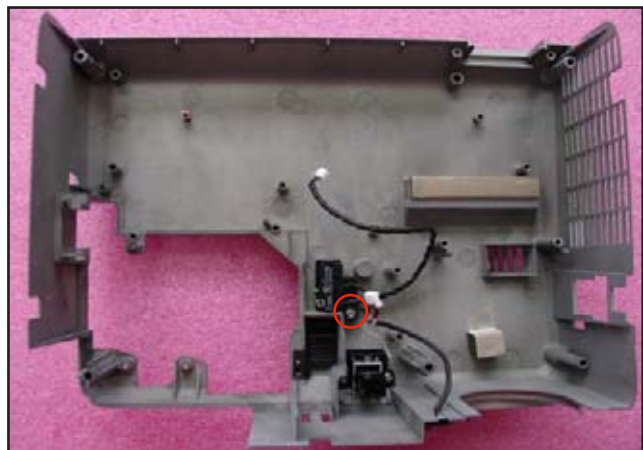

2-19 Disassemble IR Sensor Module

- 1. Tear off 1 Mylar (as red square)
- 2. Disassemble IR Sensor Board

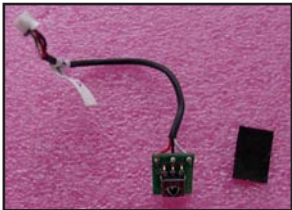

2-20 Rod Adjustment

1. Environment adjustment

- The distance between the engine and the screen is 2.36 M
- This process should be done at a dark environment. (under 5 Lux)

2. Procedure adjustment

- Change the screen to “white screen.”
- Adjust the screws by using the rod on the engine module to readjust the image. (adjust until the yellowish or bluish parts disappeared.)

3. Abnormal image inspection

- It should not have any abnormal color at the rim of the image by estimating through the eyes.

Note: - To avoid over adjust the rod.

- *“Screw 1” should be adjusted first, and then adjust the “Screw2”.After the adjustment, use the glue to fix the screws*

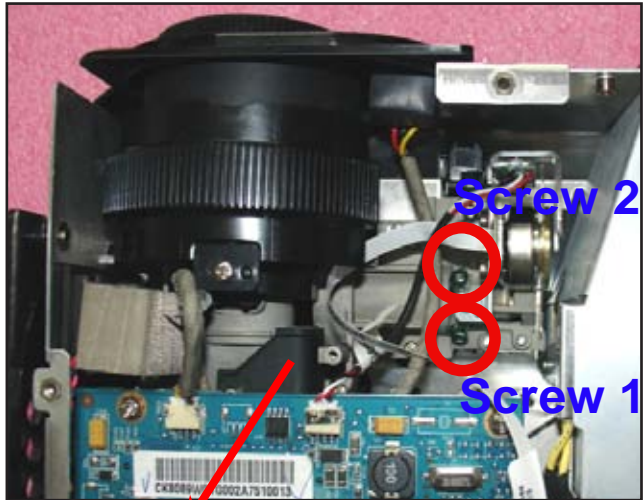

2-21 Re-write Lamp Usage Hour

1. Get into service mode

- Press (power→left→left→menu) to get into service mode

2. Choose RD Menu

3. Choose Lamp life warning test

4. Use left or right key to re-write the lamp hour back to previous lamp usage hour

5. Choose Return to Service Menu

6. Choose Exit

*Note: left key = decrease lamp hour
right key = increase lamp hour*

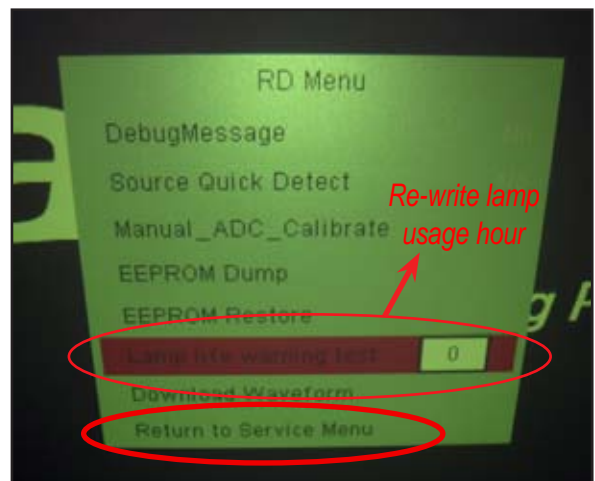

2-22 Assemble IR Sensor Module

1. Assemble IR Sensor Board in red square
2. Stick 1 Mylar.

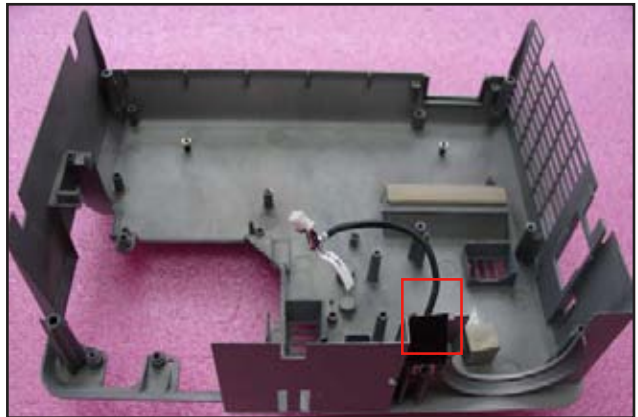
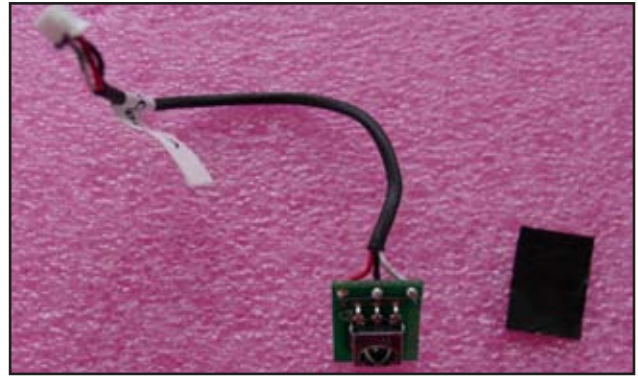

2-23 Assemble Interrupt Switch Module

1. Assemble Interrupt Switch
2. Screw 1 screw (as red circle)

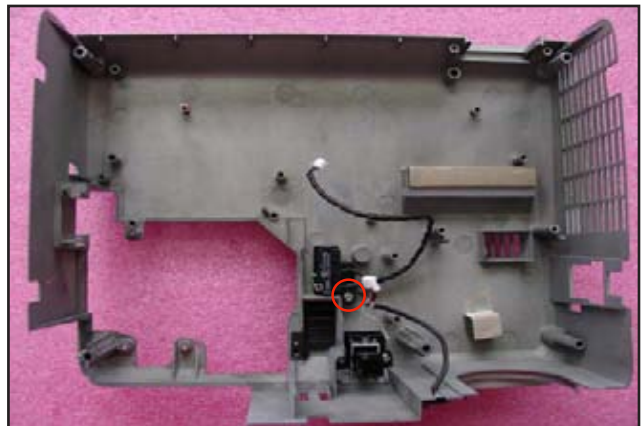

2-24 Assemble Speaker Module

1. Assemble Speaker and Rubber
2. Assemble Speaker Module

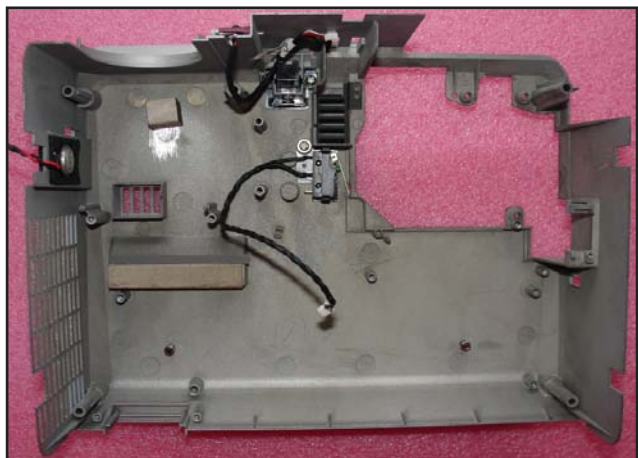
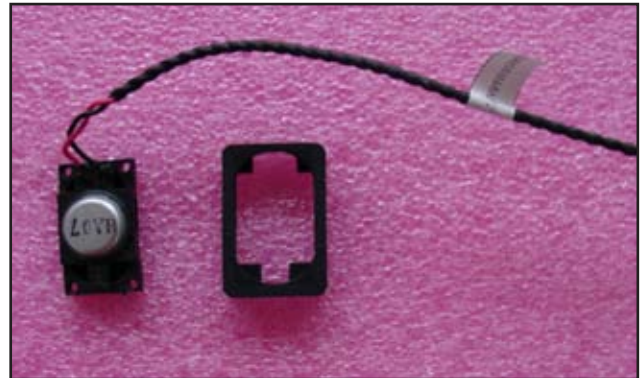

2-25 Assemble DMD Board and DMD Chip

1. Assemble DMD Chip and rotate DMD Chip Lock clockwise (as red arrow)

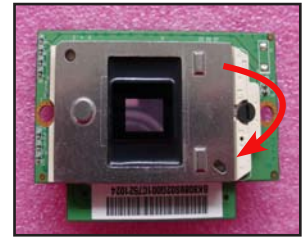
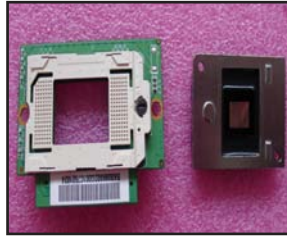

2. Assemble DMD Mask ,DMD Rubber and Heat sink

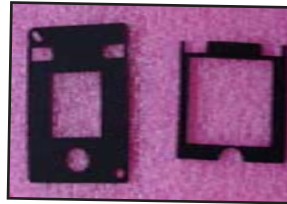

3. Screw 2 screws (as blue circle)



2-26 Assemble Engine Module

1. Assemble Focus Ring

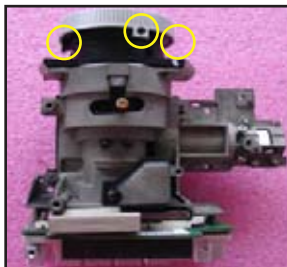

2. Screw 3 screws (as yellow circle)

3. Assemble Engine Module

4. Screw 4 screws (as red circle)

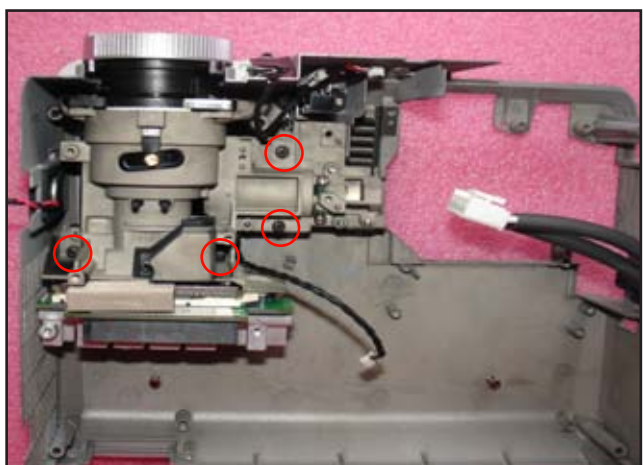

2-27 Assemble Lamp to Ballast Cable

1. Plug Lamp to Ballast Cable in yellow square



2. Screw 1 screw (as red circle)

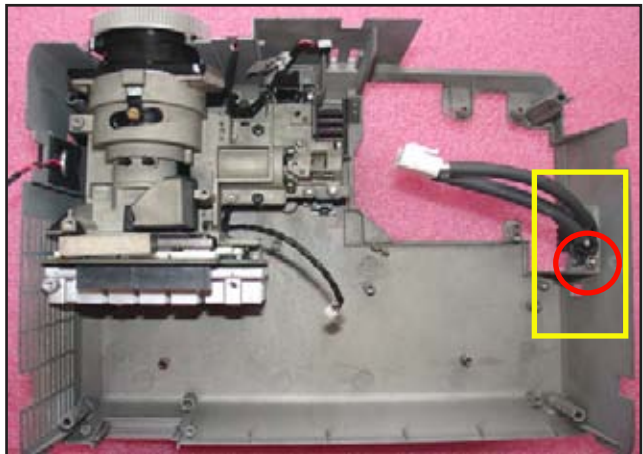

2-28 Assemble Lamp Blower Module and System Fan Module

1. Assemble System Fan and Lamp Housing

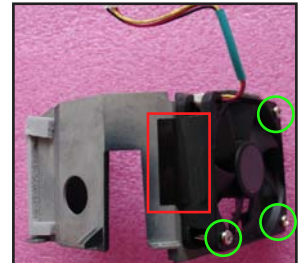
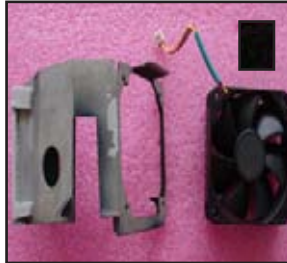

2. Screw 3 screws (as green circle)

3. Stick 1 mylar (as red square)



4. Assemble Lamp Blower , Lamp Blower Duct and Lamp Blower Holder

5. Screw 3 screws (as yellow circle)

6. Assemble Lamp Blower Module and System Fan Module

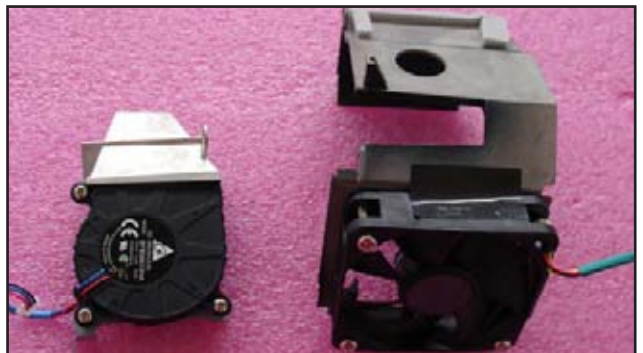

7. Screw 4 screws (as red circle)

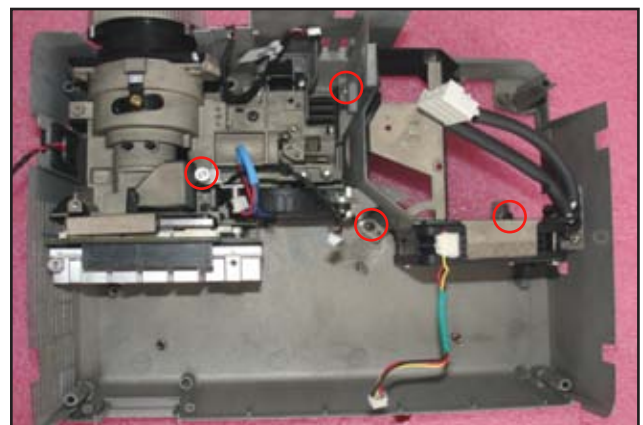

2-29 Assemble Thermal Switch Module

1. Assemble Thermal Switch



2. Screw 1 screw (as red circle)

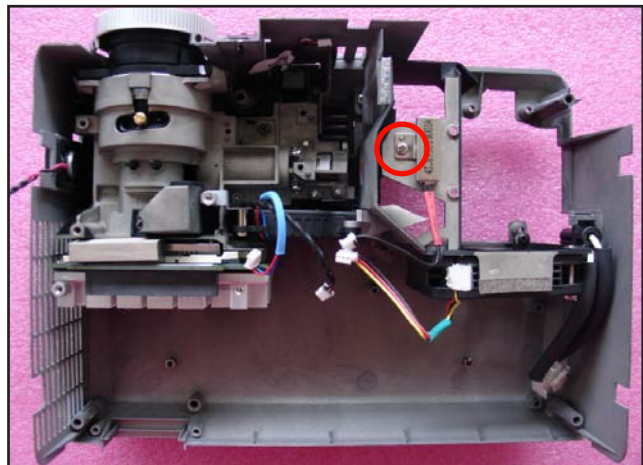

2-30 Assemble DC-DC Module

1. Plug 2 cables in red square
2. Assemble DC-DC Module
3. Screw 1 screw (as red circle)

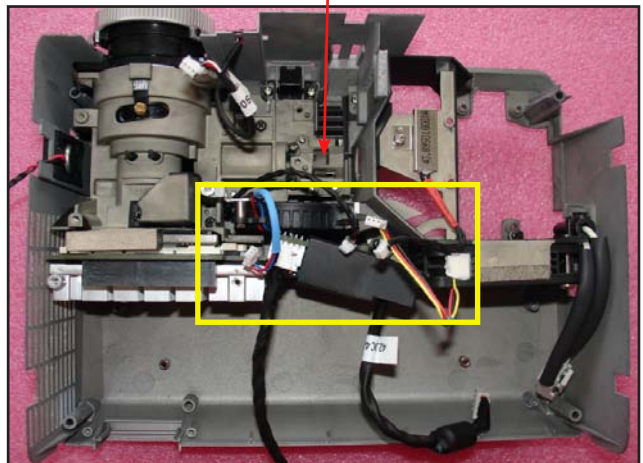
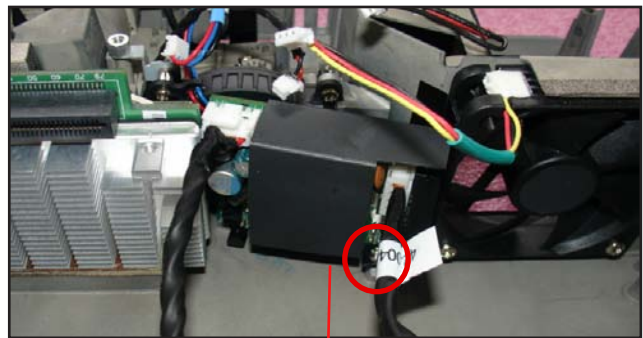
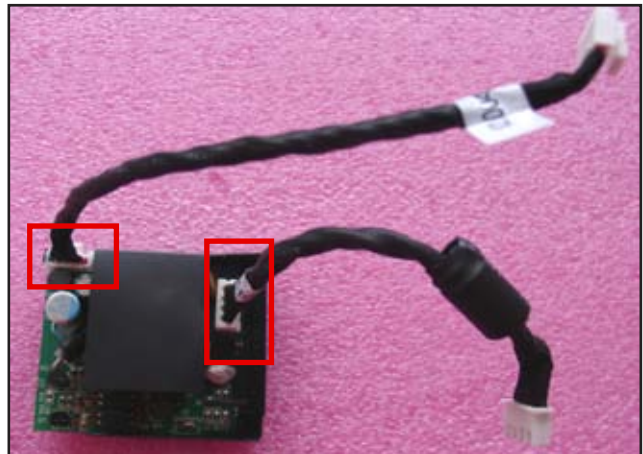

2-31 Assemble Ballast Module

1. Stick 1 mylar under Ballast Module



2. Assemble Ballast Module

3. Screw 3 screws (as yellow circle)

4. Assemble AC Inlet Bracket

5. Screw 3 screws (as red circle)

6. Plug 2 cables (as red square)

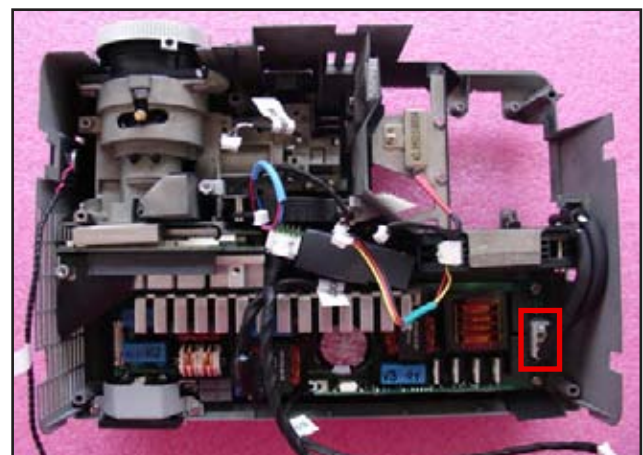
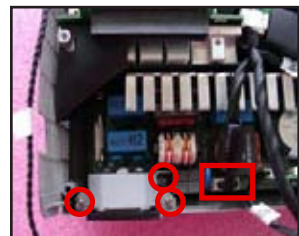
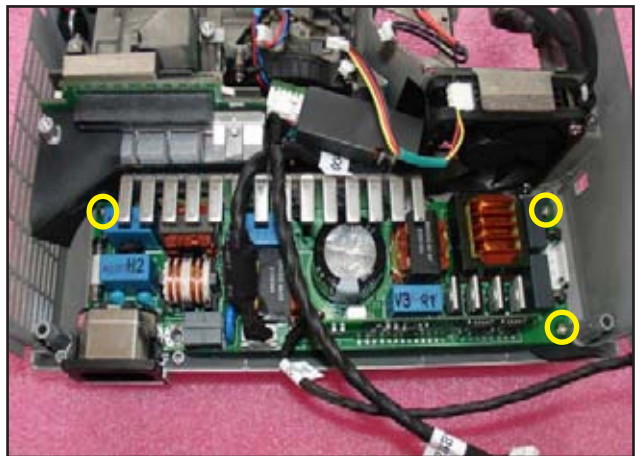

2-32 Assemble Front Cover Module

1. Assemble Front Cover Module

Note: there are 6 tenons (as red circle)



A



B



C



D

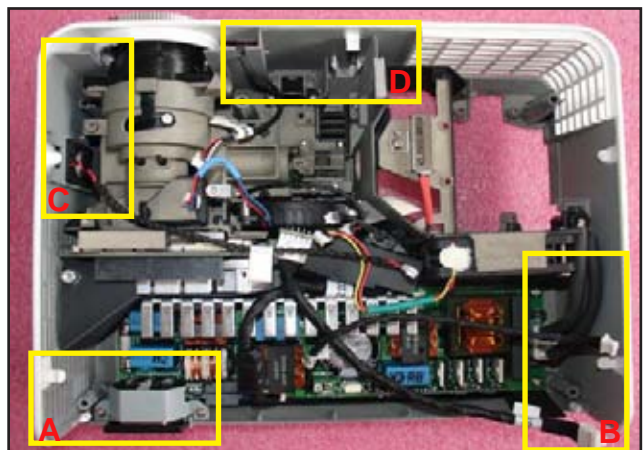

2-33 Assemble Color Wheel Module

1. Assemble Photo Sensor Board
2. Screw 1 screw (as yellow circle)
3. Assemble Color Wheel Module
4. Screw 2 screws (as red circle)

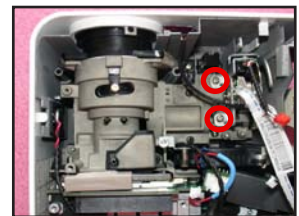
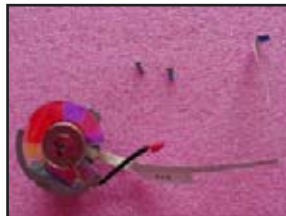
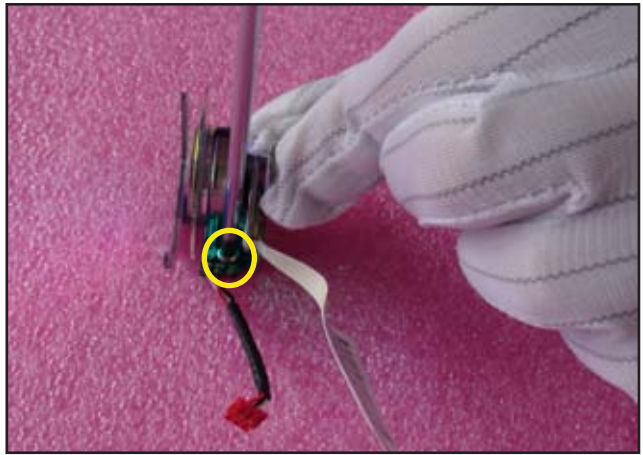
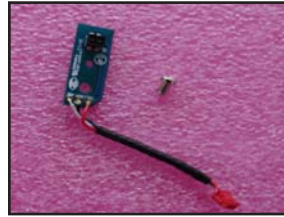

A

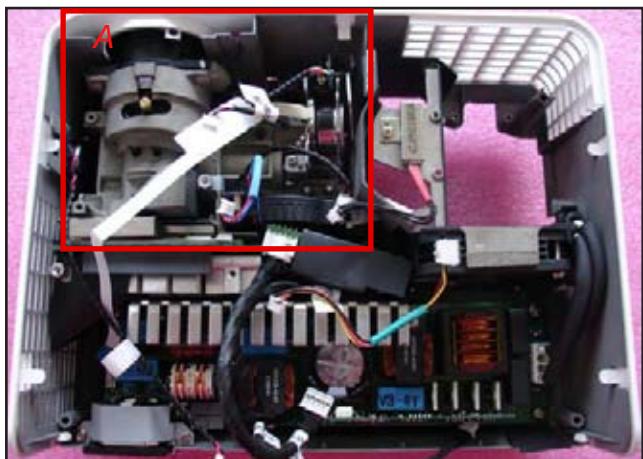

2-34 Assemble Main Board Module



1. Screw 2 screws (as red circle) to assemble the Daughter Board. (only for P3251)

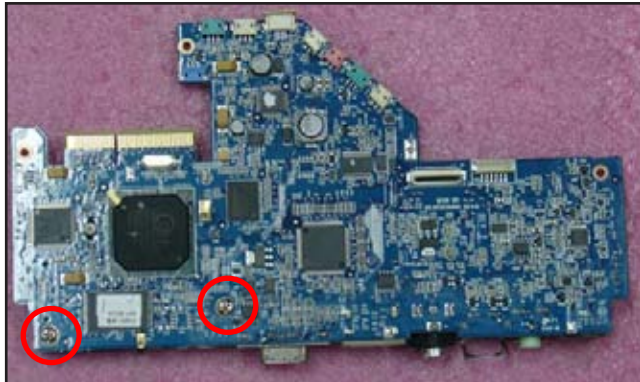

2. Plug 6 connectors (as orange square)

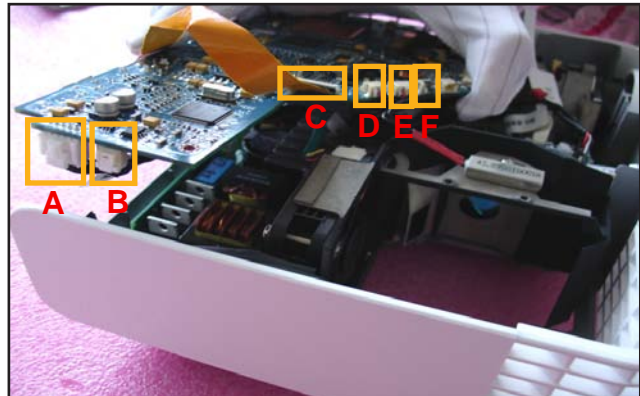

3. Assemble Main Board Module (as red arrow) and plug 1 connector (as yellow square)

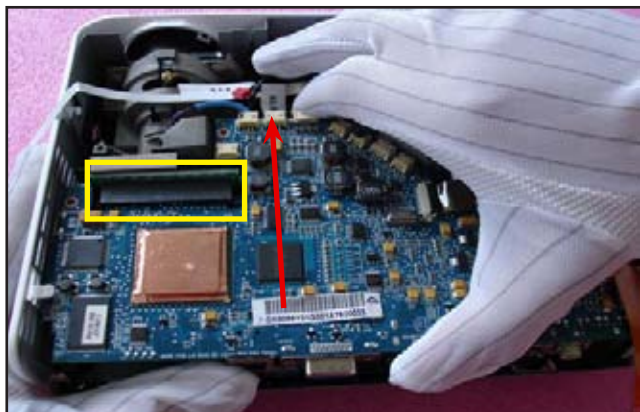

4. Plug 5 connectors (as green square)

Note: - The arrangement of cables are as follows:

- A: DC-DC 5 pin cable
- B: Ballast 5 pin cable
- C: FPC
- D: Speaker cable
- E: System Fan cable
- F: Thermal Switch cable
- G: Blower cable
- H: IR Sensor Board cable
- I: Photo Sensor Board cable
- J: Color Wheel FPC
- K: Interrupt Switch cable

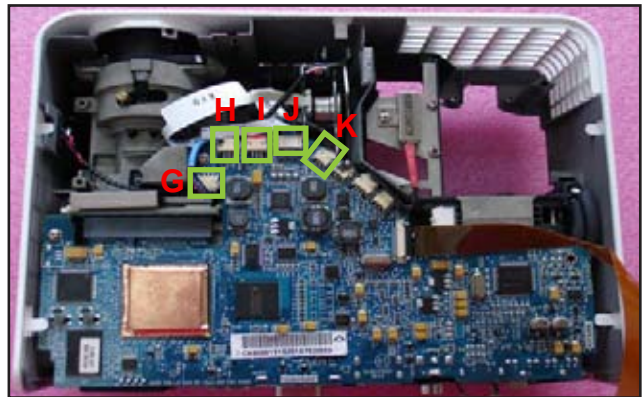

5. Stick 2 Mylars (as red square)

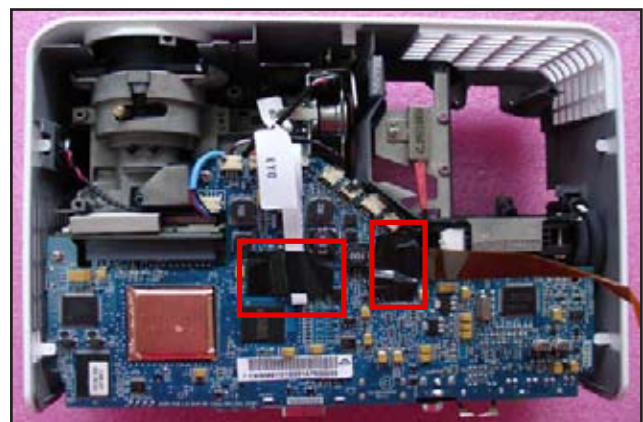

2-35 Assemble Zoom Ring Module

1. Assemble Zoom Ring on Zoom Ring Holder

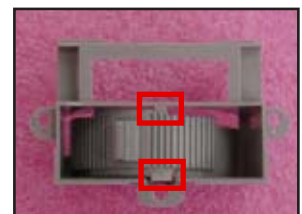

2. Assemble Zoom Ring Module on Top Cover Module



3. Screw 3 screws (as yellow circle)

Note: There are two tenons (as red square)

2-36 Assemble Key Pad Board Module

- 1. Assemble Key Pad Button and Key Pad Board on Top Cover Module
- 2. Screw 4 screws (as red circle)



2-37 Assemble Top Cover Module

1. Plug 1 FPC cable (as red square)



2. Assemble Top cover Module

3. Screw 2 Hex screws (as yellow circle)

4. Screw 5 screws (as red circle)



2-38 Assemble Lamp Module

1. Assemble Lamp Module



2. Screw 2 screws (as red circle)



2-39 Assemble Lamp Cover Module

1. Assemble Lamp Cover Module



2. Screw 2 screws (as red circle)

3. Turn over the projector, assemble OK



Troubleshooting

3-1 LED Lighting Message

Message	Power LED	Lamp LED	Temp LED
Plug-in Power Cord	Flash Red (100ms)	Flash Red (100ms)	Flash Red (100ms)
Standby Mode	Red	X	X
Power button ON	Blue	X	X
F/W Download Mode	Red	Red	Red
Lamp Ignited	Flash Blue 0.5 second H(On), 0.5 second L(Off)	X	X
Cooling Down	Flash Red 0.5 second H(On), 0.5 second L(Off)	X	X
Warning for Temperature High(On Event)	Blue	X	Red
Warning for Temperature High(On Standby)	Red	X	Red
Error for Lamp Fail(On Event)	Blue	Red	X
Error for Lamp Fail(On Standby)	Red	Red	X

Message	Power LED	Lamp LED	Temp LED
Error for Fan Fail(On Event)	Blue	X	Flash Red 0.5 second H(On), 0.5 second L(Off)
Error for Fan Fail(On Standby)	Red	X	Flash Red 0.5 second H(On), 0.5 second L(Off)
Error for Color Wheel fail / Striking Lamp Fail(On Event)	Blue	Flash Red 0.5 second H(ON), 0.5 second L(OFF)	X
Error for Color Wheel fail / Striking Lamp Fail(On Standby)	Red	Flash Red 0.5 second H(ON), 0.5 second L(OFF)	X
Burn In Lamp On	Flash Red 3 second H(On), 1 second L(Off)	X	X
Burn In Lamp Off	Flash Red 1 second H(On), 3 second L(Off)	X	X
Random Burn In	X	Red	Red

(R) - RED
(B) - BLUE
(F) - FLASH
(X) - OFF

3-2 Beep Sound

Power on (as soon as power button pressed)	So(0.3s)
Power on (lamp lighting failed)	2 x {So(0.1s) – Off(0.1s)} per lighting failure 12s interval for each trial lighting. Max 4 times of trial
Power on (lens cap was not opened, for the model with sliding lens cover only)	2 x {So(0.1s) – Off(0.1s)} periodically per 3 seconds, Totally 5 cycles. Turn off projector after 5 cycles.
Close lens cap while projector is operating (for the model with sliding lens cover only)	2 x {So(0.1s) – Off(0.1s)} periodically per 3 seconds, Totally 5 cycles. Turn off projector after 5 cycles.
Power off (power button pressed twice)	So(0.3s)
Fan lock	So(0.1s) periodically per second
Overheat	2 x {So(0.1s) – Off(0.1s)} periodically per second
Lamp error	3 x {So(0.1s) – Off(0.1s)} periodically per second
Lamp Life reminding	3 x {Do(0.2s) – Off(0.8s) – So(0.2s) – Off(0.8s)} with reminding message
Presentation Timer (time is up)	3 x {Do(0.1s) – Off(0.9s)} - So(0.5s)

3-3 Main Procedure

No	Symptom	Procedure
1	No Power	<ul style="list-style-type: none"> • Ensure the Power Cord and AC Power Outlet are securely connected • Check Lamp Cover and Interrupt Switch • Ensure all connectors are securely connected and aren't broken • Check Lamp Driver • Check LVPS • Check Main Board
2	Auto Shut Down	<ul style="list-style-type: none"> • Check LED Status <ul style="list-style-type: none"> a. Power LED on(B/R), Lamp LED off, Temp LED on (R) <ul style="list-style-type: none"> • Check Thermal Switch • Check Fan b. Power LED on(B/R), Lamp LED on (R), Temp LED off <ul style="list-style-type: none"> • Check Lamp • Check Lamp Driver • Check Main Board c. Power LED on(B/R), Lamp LED off, Temp LED flash (R) <ul style="list-style-type: none"> • Check Fan • Check Main Board d. Power LED on(B/R), Lamp LED flash (R), Temp LED off <ul style="list-style-type: none"> • Check Color Wheel • Check Photo Sensor Board

No	Symptom	Procedure
3	No Image	<ul style="list-style-type: none"> • Ensure the Signal Cable and Source work (If you connect multiple sources at the same time, use the “Source” button on the control panel to switch) • Ensure all connectors are securely connected and aren’t broken • Check Main Board • Check DMD Board • Check Colour Wheel • Check DMD Chip • Check Engine Module
4	No Light On	<ul style="list-style-type: none"> • Ensure all connectors are securely connected and aren’t broken • Check Lamp Module • Check Lamp Driver • Check LVPS • Check Main Board
5	Mechanical Noise	<ul style="list-style-type: none"> • Check Colour Wheel • Check Fan Module
6	Line Bar/Line Defect	<ul style="list-style-type: none"> • Check if the Main Board and the DMD Board are assembled properly • Check Main Board • Check DMD Board • Check DMD Chip

No	Symptom	Procedure
7	Image Flicker	<ul style="list-style-type: none"> • Do “Reset (All data)” of the OSD Menu • Ensure that the signal cables and source are work as well- Check Lamp Module • Check Colour Wheel • Check DMD Board • Check Main Board
8	Colour Abnormal	<ul style="list-style-type: none"> • Do “Reset (All data)” of the OSD Menu • Adjust Colour Wheel Index • Check Main Board • Check DMD Board • Check Colour Wheel
9	Poor Uniformity/ Shadow	<ul style="list-style-type: none"> • Ensure the projection screen without dirt • Ensure the projection lens is clean • Ensure the Brightness is within spec • Check rod alignment • Check Engine Module
10	Dead Pixel/Dust (Out of spec.)	<ul style="list-style-type: none"> • Ensure the projection screen without dirt • Ensure the projection lens is clean • Check DMD Chip and Engine Module • Check DMD Chip • Check Engine Module
11	Garbage Image	<ul style="list-style-type: none"> • Ensure that the signal cables and source work as well. • Check Main Board • Check DMD Board
12	Remote Control/ Control Panel Failed	<ul style="list-style-type: none"> • Remote Control <ul style="list-style-type: none"> a. Check Battery b. Check Remote Controller c. IR Sensor Board d. Check Main Board • Control Panel <ul style="list-style-type: none"> a. Check FPC b. Check key pad c. Check Main Board

No	Symptom	Procedure
13	Function Abnormal	<ul style="list-style-type: none"> • Do "Reset (All data)" of the OSD Menu • Check Main Board • Check DMD Board
14	Audio Abnonrmal	<ul style="list-style-type: none"> • Ensure that the signal cables and source are work as well • Check Speaker Module • Check Main Board
15	FW Upgrade Failed	<ul style="list-style-type: none"> • Ensure that the signal cables and PC are work as well • Check the software program version • Check the firmware file • Check the upgrade process • Check Main Board
16	Forgetting Password (adminstrator Password)	<ul style="list-style-type: none"> • Security Card. This unique password is a back door of Administrator Password which will be accepted by projector anytime no matter what the Administrator Password is. • How to get the Universal Password? <ol style="list-style-type: none"> (1) Click the "AcerSNID" <div data-bbox="794 1003 1056 1093" data-label="Image"> </div> (2) Input SNID number.(SNID number is on the Security Card) <div data-bbox="767 1234 1011 1462" data-label="Image"> </div> (3) Click "Calculate".Then the Universal Password will appear. <div data-bbox="767 1621 1086 1910" data-label="Image"> </div>

No	Symptom	Procedure
17	SD Card/ USB flash disk Function Failed	<ul style="list-style-type: none">• Ensure that the signal cables and source work as well.• Check Main Board• Check Daughter Board

Function Test & Alignment Procedure

4-1 Test Equipment Needed

- IBM PC with SVGA/XGA resolution
- DVD player with Multi-system (NTSC/PAL/SECAM), equipped "Component", "S-Video", "Composite" and "HDMI".
- HDTV Source (480P, 720P, 1080i)
- Minolta CL-100
- Quantum Data 802B or CHROMA2327 (Color Video Signal & Pattern Generator)
- After changing parts, check the information below.

4-2 Service Mode

1. Turn on the projector and input the signal
2. Do the following actions sequentially to enter service mode menu
 - (1) Press "Power→Left→Left→Menu".
 - (2) Service mode will be shown.
 - (3) After confirming the configuration, press "Exit" to exit.

4-3 OSD Reset

1. After final QC step, we have to erase all saved change again and restore the OSD default setting. The following actions will allow you to erase all end-users' settings and restore the default setting:
 - (1) Please enter OSD menu.
 - (2) To execute "Reset" function.

4-4 Test Condition

- Circumstance brightness: Dark room less than 5.0 lux.
 - Inspection distance: 1.8m~2.5m functional inspection.
 - Screen size: 60 inches diagonal
 - After repairing each P3150/P3250/P3150 refresh/P3250 refresh/P3251
- , the unit should be run-in (refer to the table below)

Symptom	Run-in Time
Normal repair	2 hours
NFF	4 hours
Auto shut down	6 hours

- Enter Burn-In Mode

* Cycle setting is based on the defect symptoms. ie: If it is NFF, the run-in time is 4 hours. You have to set the lamp on for 50 min. and lamp off for 10 min for 4 cycles.

Press Power > Left > Left > Menu	
Choose Burn-In Test > enter	
Lamp On (Min)	Press right key to adjust the time (50)
Lamp Off (Min)	Press right key to adjust the time (10)
Set burn in cycle	Press right key to adjust the cycle
After setting up the time, choose Burn-In mode and hit enter	

Screen Defects (While replacing DMD Chip, DMD BD and MB)

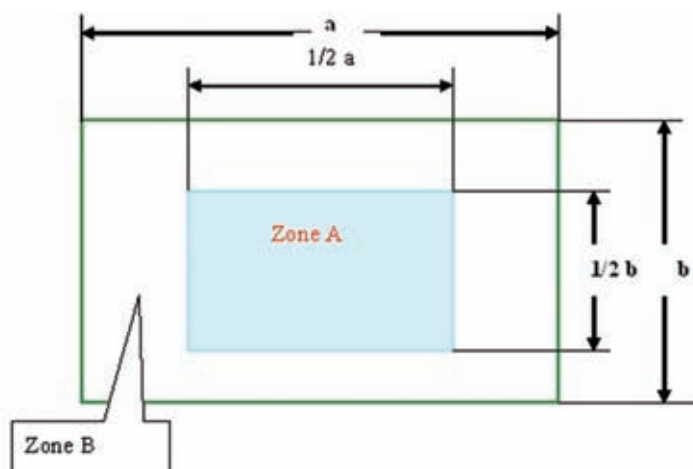

< Figure: Zone A & B Definition >

Defect specification table

Order	Symptom	Pattern	Criteria
1	Bright pixel (dots)	Gray 10 pattern	$A+B \leq 1$
2	Dark pixel (dots)	White pattern	$A+B \leq 6$
3	Bright blemish	Gray 15 pattern	$A+B \leq 10$
4	Dark blemish	Blue 60 pattern	$A+B \leq 10$
5	Bright dot on frame	Gray 10 pattern	≤ 1
6	Unstable pixel	White & Black pattern	$A+B \leq 1$
7	Adjacent dark pixel	White & Black pattern	$A+B = 0$

4-5 Test Inspection Procedure

Change parts/ Update	M/B	FW	Color Wheel	Lamp Module	Engine	EDID	Lamp Driver
Version Update	v	v				v	
Color Wheel Index	v		v				
Reset lamp hour				v			
OSD Reset	v	v					
EDID	v						
Re-write Lamp Hour Usage	v						
Check ROD Position and Adjust					v		
Reset Dafult Language (for refresh models/ P3251)	v	v				v	
Waveform Download (for refresh models)	v	v					v

4-6 PC MODE

NOTE: Test Signal: analog 800x600 @60Hz(P3150/P3150 refresh), analog 1024x768 @60Hz(P3250/P3250 refresh/P3251). Take P3250 for example.

1. Frequency and tracking boundry

Procedure

- Test equipment: video generator.
- Test signal: analog 1024 x 768@60Hz
Partern: general-1 or master
- Check and see if the image sharpness is well-performed.
- If not re-adjust by the following steps:
 - (1) Select "Frequency" to adjust pixel number of pixel clock in one line period.
 - (2) Select "Tracking" and use right or left arrow key to a value to minimize video flicker.

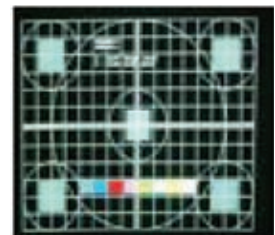

General-1



Master

Inspection item	<ul style="list-style-type: none"> - Adjust Resync or Frequency/Tracking/H. Position/V. Position to the inner screen. - Eliminate visul wavy noise by Rsync, Frequency or Tracking selction. - Check if there is noise on the screen. - Horizontal and vertical position of the vedio should be adjustable to the screen frame.
Criteria	<ul style="list-style-type: none"> - If there is noise on the screen, the product is considered as failure product. - If there is noise on the screen, use auto or manual "frequency" function or "tracking" function to adjust the screen. - The PC mode functionally sure be workable include support format with frequency and auto detected functional will be workable.

2. Bright Pixel

Procedure	<ul style="list-style-type: none"> - Test equipment: video generator - Test signal: analog 1024 x 768@60Hz - Test Pattern: Gray 10
Inspection item	<ul style="list-style-type: none"> - Bright pixel check.
Criteria	<ul style="list-style-type: none"> - Bright pixel should be no more than 1 under gray 10 pattern. - Adjacent pixels are unacceptable. - Ref. Defect specification table.

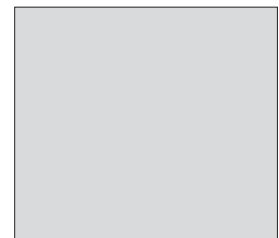

Gray 10

3. Dark Pixel

Procedure	<ul style="list-style-type: none"> - Test equipment: video generator - Test signal: analog 1024 x 768@60Hz - Test Pattern: Full white
Inspection item	<ul style="list-style-type: none"> - Dark pixels check.
Criteria	<ul style="list-style-type: none"> - The dark pixel should be no more than 6 under full white pattern. - Adjacent pixels are unacceptable. - Ref. Defect specification table.



Full white

4. Bright Blemish

- Procedure
- Test equipment: video generator
 - Test signal: analog 1024 x 768@60Hz
 - Test Pattern: Gray 15
- Inspection item
- Bright blemish check.
- Criteria
- The bright blemish should be no more than 10 under gray 15 pattern.
 - Ref. Defect specification table.

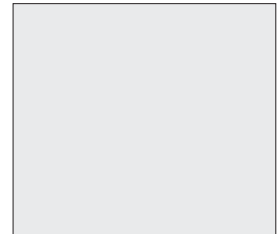

Gray 15

5. Dark Blemish

- Procedure
- Test equipment: video generator.
 - Test signal: analog 1024x768@60Hz.
 - Test Pattern: Blue 60
- Inspection item
- Dark blemish check.
- Criteria
- The dark blemish should be no more than 10 under blue 60 pattern.
 - Ref. Defect specification table



Blue 60

6. Focus test

- Procedure
- Test equipment: video generator.
 - Test signal: analog 1024 x 768@60Hz
 - Test Pattern: Full screen
- Inspection item
- Focus check
- Criteria
- From screen 2 M via visual to check the focus, look at the entire screen, focus shall be clear, crisp, and sharp over the entire surface of the display pattern. (Blur word on one of the corner after adjustment is acceptable. However, the word should at least be recognizable.)

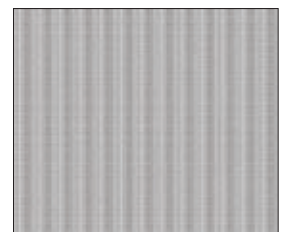

Full screen

7. Color performance

Procedure	<ul style="list-style-type: none"> - Test equipment: video generator. - Test signal: 480p, 720p, 1080p - Test Pattern: Master, 64 gray RGBW or SMPTE bar <p>* Please refer to 4-2 to get into service mode. Use 720p & 1080p signal, master pattern to do HDTV test. Color cannot discolor to purple and blue.</p>
Inspection item	<ul style="list-style-type: none"> - Check if each color level is well-functioned. - Color saturation
Criteria	<ul style="list-style-type: none"> - Screen appears normal. It should not have any abnormal condition, such as lines appear on the screen and so on. - Color appears normal. - It is unacceptable to have few lines flashing. - RGBW should all appear normal on the screen and sort from R -G-B-W. - Color levels should be sufficient and normal. (The unidentified color levels on both left and right sides should not over 4 color levels.) - Gray level should not have abnormal color or heavy lines. - If color appears abnormal, please get into service mode to do color wheel index adjustment.

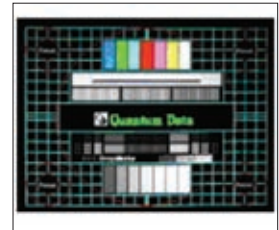

Master



64 gray RGBW

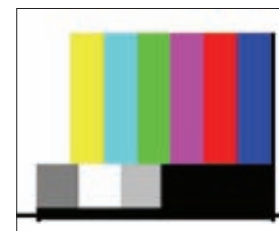

SMPTE BAR

4-7 Video Performance

1. CVBS

Procedure	<ul style="list-style-type: none"> - Test equipment: DVD player - Test signal: CVBS
Inspection item	<ul style="list-style-type: none"> - Video performance test
Inspection Distance	<ul style="list-style-type: none"> - 1.8M ~2.5M
Criteria	<ul style="list-style-type: none"> - Check any abnormal color, line distortion or any noise on the screen.



SMPTE RP-133

- Check the sound from speakers.

2. S-Video

- Procedure
- Test equipment: DVD player
 - Test signal: S-Video
- Inspection item
- Video performance test
- Inspection Distance
- 1.8M ~2.5M
- Criteria
- Check any abnormal color, line distortion or any noise on the screen.
 - Check the sound from speakers.

3. HDTV/ Component

- Procedure
- Test equipment: DVD player
 - Test signal: Ycbcr/YPbPr
- Inspection item
- HDTV performance test
- Inspection Distance
- 1.8M ~2.5M
- Criteria
- Check any abnormal color, line distortion or any noise on the screen.
 - Check the sound from speakers.



Motion video

4. Audio Test

- Procedure
- Test equipment: DVD player
 - Test signal: CVBS
- Inspection item
- Audio performance test
- Inspection Distance
- 1.8M ~2.5M
- Criteria
- Check the sound from speakers.
 - Check "Volume" is normal
 - Check "Mute" is normal

5.HDMI Test

Procedure	<ul style="list-style-type: none">- Test Signal : 720p,1080i- Test Pattern : Any Pattern- Equipment: DVD Player with HDMI output- Display type must be set to 16:9
Inspection item	<ul style="list-style-type: none">- HDMI Test
Criteria	<ul style="list-style-type: none">- Ensure if the image is well performed and the color can not discolor.

4-8 Optical Performance Measure

Inspection Condition
<ul style="list-style-type: none">- Environment luminance: 5 Lux- Product must be warmed up for 3 minutes- Distances from the screen: 2.36 M- Screen Size: 60 inches diagonal- Reset to default before measurement

1. Test equipment

Procedure	<ul style="list-style-type: none">- Press "Power→Left→Left→Menu".- Select "Spoke Test"
-----------	---

2. Brightness

- Procedure
- Full white pattern
 - Use CL100 to measure brightness values of P1~P9.
 - Follow the brightness formula to calculate brightness values.
- ☀ Brightness Formula
- $$\text{Avg.}(P1 \sim P9) \times 1.1 \text{m}^2$$
- Criteria
- 900 lumens

3. Full On/Full Off Contrast

- Procedure
- Full white pattern & full black pattern
 - Use CL100 to measure brightness values of full white pattern P5 & full black pattern B5 (see image: full white)
 - Follow Contrast formula to calculate contrast values.
- ☀ Contrast Formula
- $$P5/B5$$
- Note: P5=center of white image
B5=center of black image.
- Criteria
- 1400:1

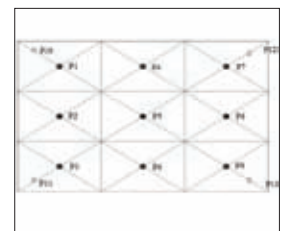

Full white pattern

4. Uniformity

- Procedure
- Full white pattern
 - Use CL100 to measure brightness values of P1~P9 (see image: full white).
 - Follow the Uniformity formula to calculate average values.
- ☀ Uniformity Formula
- $$\text{ANSI Uniformity} = \frac{\text{Avg.}(P1, P3, P7, P9)}{P5} \times 100\%$$
- Criteria
- 65%



Full black pattern

4-9 SD Card /USB flash disk Test (only for P3251)

1.SD Card Test

Procedure

- Test equipment: SD Card(include test pattern),
- Test Pattern: WhiteBlack,Graystep16, ColorBar
- Turn on the projector and plug SD Card into the projector.
- Select “SD”-->”Photo”, play the test pattern in SD Card.
- Press “2” button on remote controller when play the WhiteBlack test pattern.
- Get into service mode (Please refer to 4-2).
- Select “Analog Settings”-->”MMS Calibration”
- “Success” will appear on MMS Calibration.
- Press”2” button on remote controller to play the test pattern.

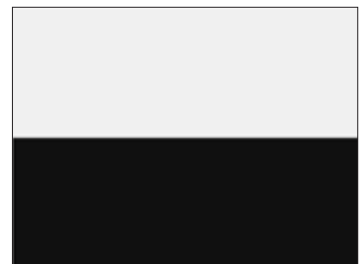

WhiteBlack_640x480

Inspection item

- Check if each color level is well-functioned.
- Color saturation

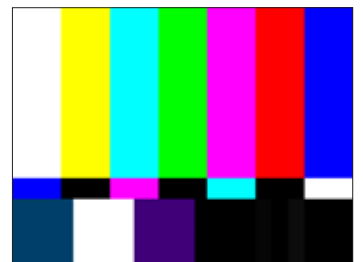

ColorBar_640x480

Criteria

- Screen appears normal. It should not have any abnormal condition, such as lines appear on the screen and so on.
- Color appears normal.
- It is unacceptable to have few lines flashing.

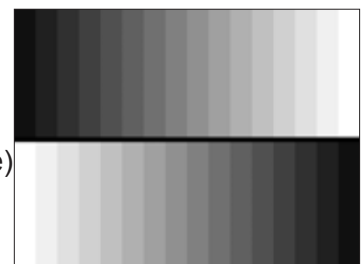

GrayStep16_640x480

2. USB flash disk Test

Procedure

- Test equipment: USB flash disk(include video file)
- Test Pattern: video file.
- Turn on the projector and plug USB flash disk into the projector.
- Select “USB”-->”Video”, play video file in USB flash disk.

Inspection item

- Check any abnormal color, line distortion or any noise on the screen.
- Check the sound from speaker.

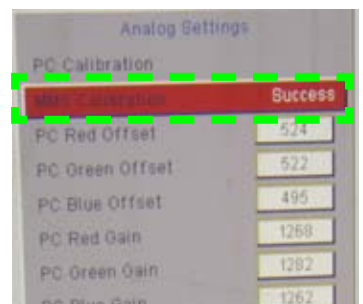

Criteria

- Screen and sound appears normal.

4-10 Others

1. Functional Inspection

- Keypad button - All keypad buttons must operate smoothly.
- General - All OSD functions must be checked for functionality. When OSD menu is displayed, there shall be no visible peaking, ringing, streaking, or smearing artifacts on the screen.
- Factory Default - The factory settings (with appropriate centering, size, geometry distortion, etc.) shall be displayed upon "Recall" is selected from OSD
- Display Size - All preset modes shall expand to full screen size using OSD Horizontal and Vertical Size controls
- Display Data Channel (DDC) - The purpose of the DDC test is to verify the DDC1/DDC2B operation of the projector and to verify Plug & Play function.
- Acoustic - High pitch sound from cooling fan and color wheel is unacceptable.

2. Check points for exterior and print pattern

Check item	Check point
Text & Pattern	Missing letters & pattern or blurry prints are unacceptable.
Exterior	Dirt, scrape, water ripples and uneven color are unacceptable.
Buttons	Stuck buttons are unacceptable.
Focus ring	Focus ring is functioning smoothly.
Logo	Missing logo, missing prints and blurry prints are unacceptable
Screw	All screw sure be fixed and in right type.
Pedestal	Well-functioned
Lamp Cover	It should be locked in the correct place.
Plastic Parts	All plastic parts can not be brocken and damaged.
Safety or warning label	All safety and warning label should be visible, including all contents.
Connector	All interface connector should be complete and workable.

Firmware Upgrade

Section 1: System Firmware Upgrade

5-1 Equipment Needed

Software :

- DLP Composer
- Firmware
- 8M Flash (8M flash has to put in PC and set right path in 5-5 step4)

Hardware :

- Projector
- Power cord (42.53506G002)
- USB Cable (42.87304G001)
- PC or Laptop

Note: The FW upgrade procedure for P3150/P3250/P3150refresh/P3250 refresh/P3251 is the same. Here, we take P3250 as an example.



5-2 DLP Composer Lite Setup Procedure

1. Choose "DLP Composer Lite V7.1 Setup" Program.
2. Click Next button.
3. Read License Agreement.
 - Choose I accept and agree to be bound by all the terms and conditions of this License Agreement.
4. Click Next.
5. Click "Next".

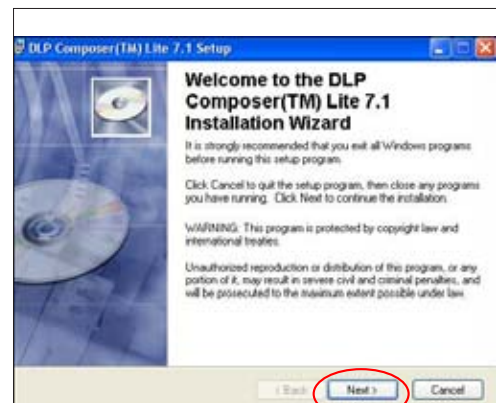

6. Click Next.

7. Click Next.

8. Writing system registry values.

9. Click Finish.

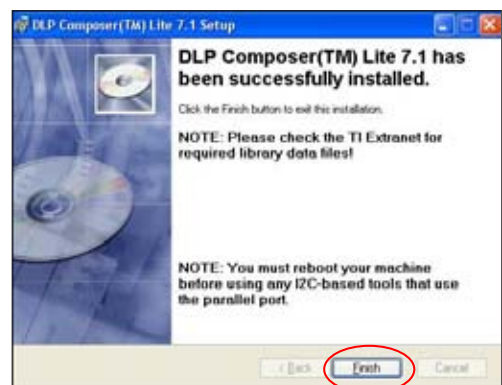
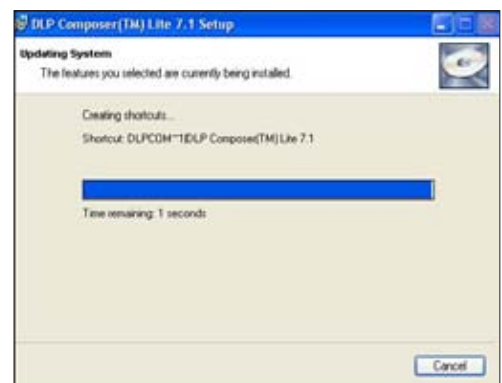
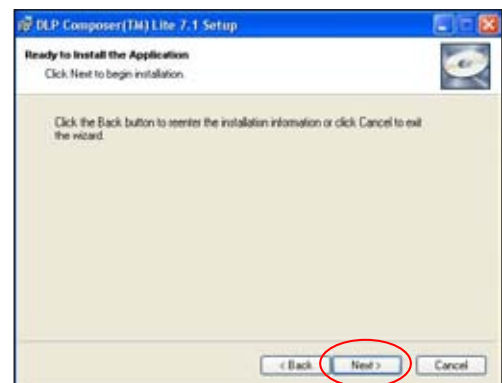
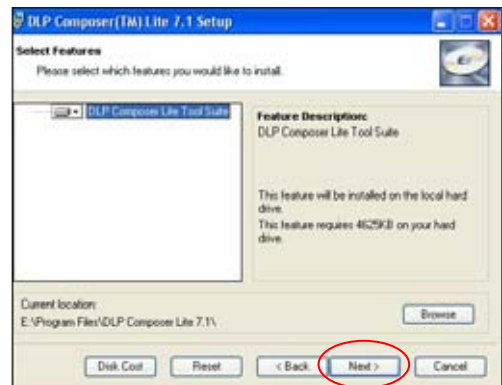

5-3 USB Driver Upgrade Procedure

1. Set up

- Plug in power cord and then press "Power" and "Menu" button simultaneously hold on about 5 seconds, release "Power" and "Menu" button
- Once the Power ,Lamp and Temp LED light on RED at the same time, plug in USB cable into the projector and link to the USB port of a PC.

2. Execute Program

- Found new hardware wizard will be appeared on the screen.
- Select Install the software automatically (Recommended).
- Then click Next.



3. Finish

- Click Finish to end the installation.



5-4 Firmware Upgrade Procedure

1. Set-up

- Plug in power cord and then press "Power" and "Menu" button simultaneously hold on about 5 seconds, release "Power" and "Menu" button
- Once the Power ,Lamp and Temp LED light on RED at the same time, plug in USB cable into the projector and link to the USB port of a PC.



2. Execute the DLP Compose™ file.

3. Click edit and preferences.

4. Click "Library."

- Click the "browse" button and navigate to the directory where you put the library file in.

Note: P3251's library need to use the library in "DLP Composer Lite v9.2" .

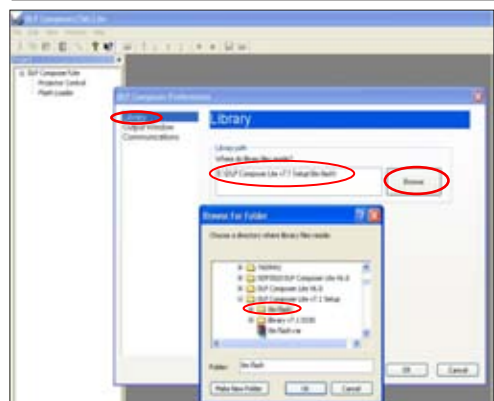
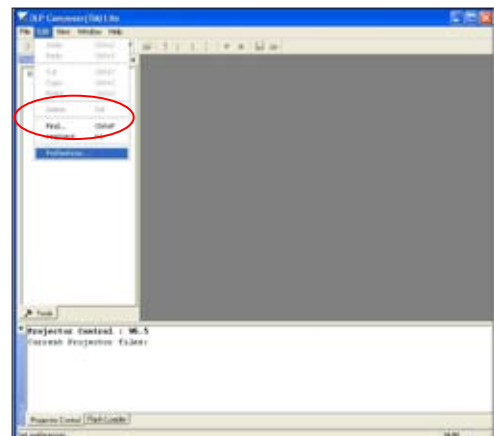

5. Select Edit\preferences\Communications

- Choose USB".
- Click OK".

6. Choose Flash Loader.

- Click Browse to search the firmware file.

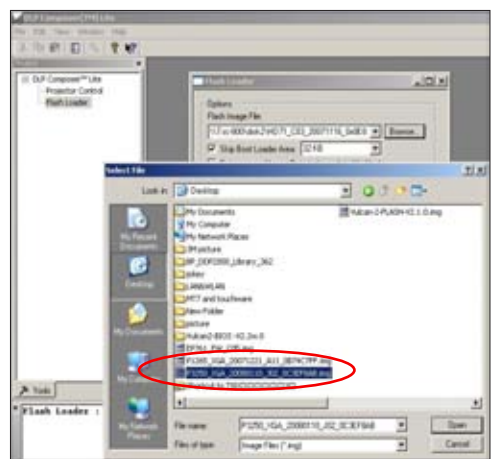
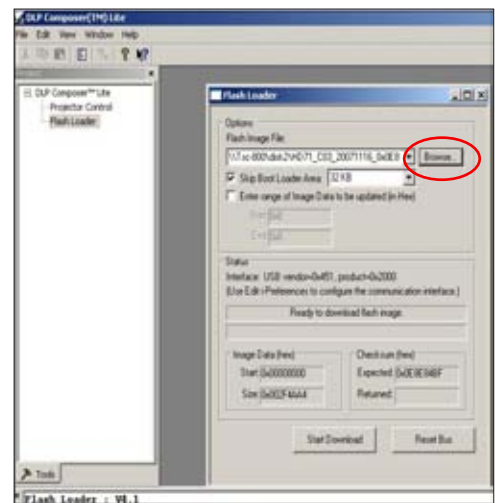
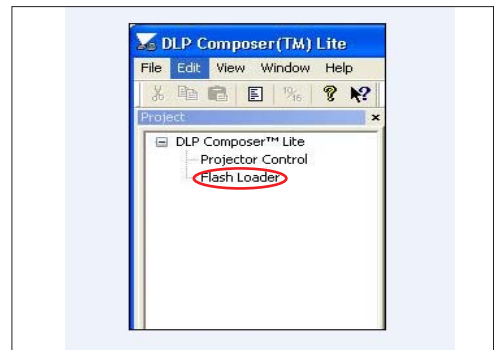
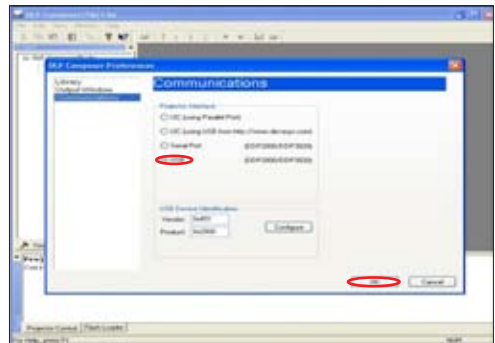

7. Select the item skip Boot Loader Area (select 32KB).

- Click Reset Bus to erase the flash memory.

8. If the firmware is ready, click start download to process the firmware upgrade.

- Click Yes to erase the flash memory.

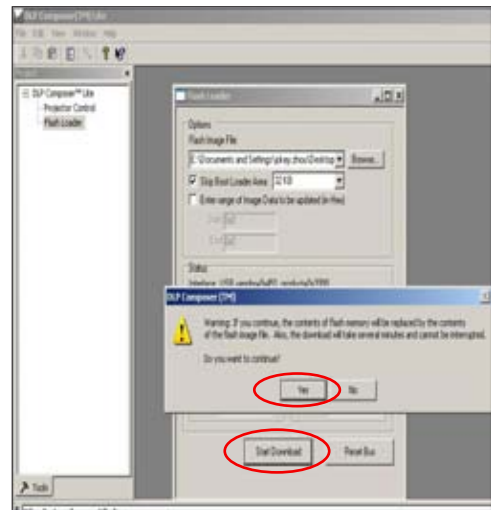
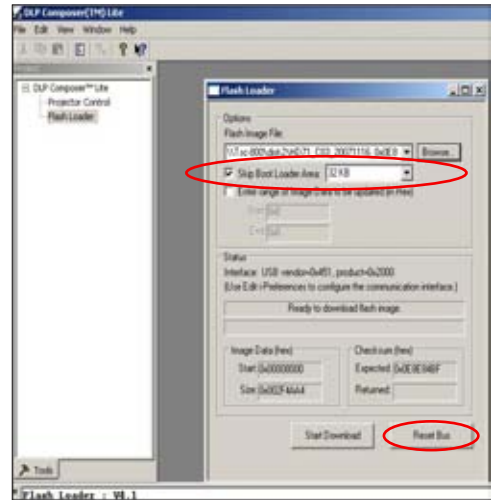

9. When firmware upgrade process is finished the unit return to stand-by status. The Power LED lights on Red.

- Unplug USB cable and power cord and replug in power cord.

10. Restart the unit and enter the service mode to check the firmware version. (To enter service mode, please refer to Chapter 4 Function Test and Alignment Procedure.)

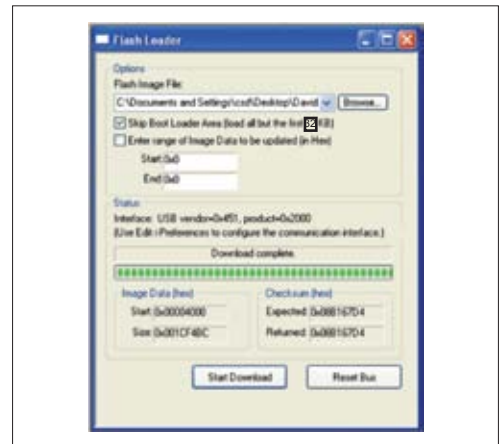

Section 2 : Waveform Download

5-5 Waveform Download (for refresh models)

1. Hold on the “Up” button, then plug Power Cord in, the Power LED lights on red. After about 5 seconds release “Up” button, Power LED turns to blue and Temp LED will flash for 4 seconds. After that, Temp LED and Lamp LED light on red, and Power LED lights blue.
2. Re-plug in power cord and turn on this projector. If the image is steady, the process is ok!

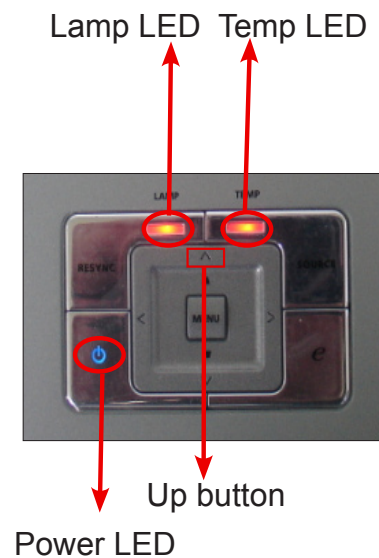

*Note: This step must be executed after FW,
Main Board or Lamp Driver changed*

5-6 Waveform Download (for P3251)

1. Hold on the "Power" button, then plug Power Cord in, After about 4 seconds, release "Power" button, at the same time the Lamp LED flash red.
2. After about 10 seconds, Power LED lights red, the message means success download.
3. Re-plug in power cord and turn on this projector. If the image is steady, the process is ok!

*Note: This step must be executed after FW,
Main Board or Lamp Driver changed*

Section 3 : Multi-Media Firmware Upgrade (only for P3251)

5-7 Equipment Needed

Software :

- 1201 tool
- Firmware (*.fwu)

Hardware :

- Projector
- Power cord (42.53506G002)
- USB Cable (male to male)
- PC or Laptop



5-8 USB Driver Upgrade Procedure

1. Set up

- Hold on "Power" and "Menu" button and then Plug in power cord , hold on about 5 seconds, release "Power" and "Menu" button , the Power Lamp and Temp LED light RED at the same time.
- Plug in USB cable into the projector and link to the USB port of a PC.

2. Execute Program

- 1) Found new hardware wizard will be appeared on the screen.
 - Select "Install from a list or specific location (Advanced)"
 - Then click Next.
- 2) - Click "Browse" button to choose "1201 tool"
 - Select "OK" ,
 - Then click Next.

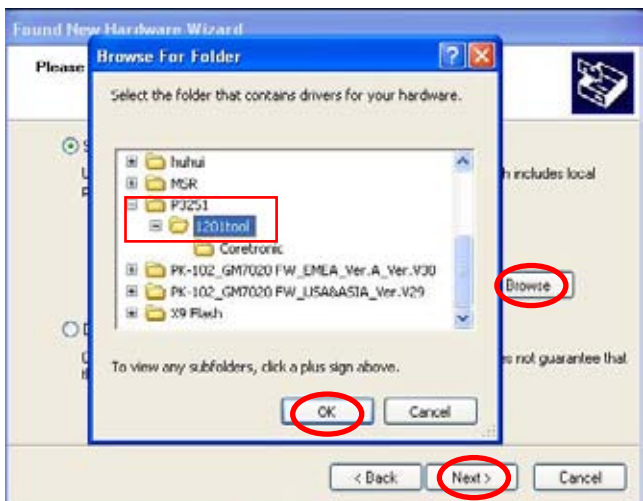

3) Click "Continue Anyway".



4) Click "Finish" to end the installation.



5) Found new USB Root HUB will be appeared on the screen.



4. Click "Download."

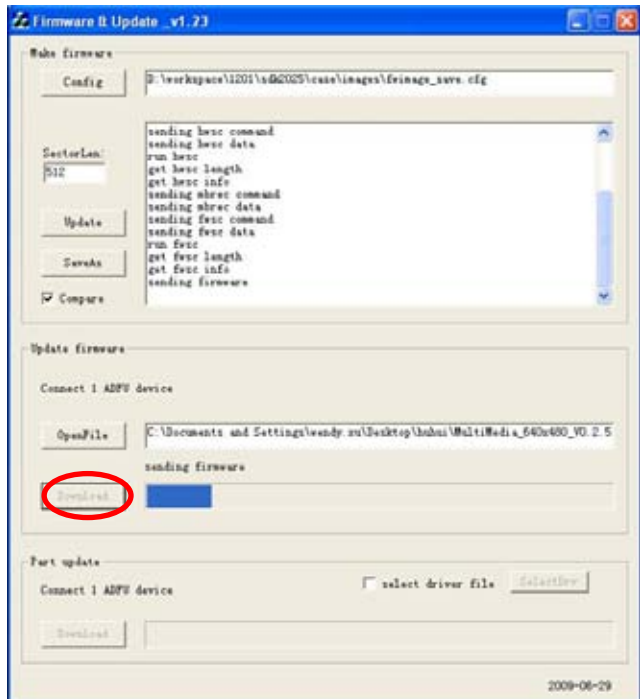

5. The success information will show on screen (as red square)

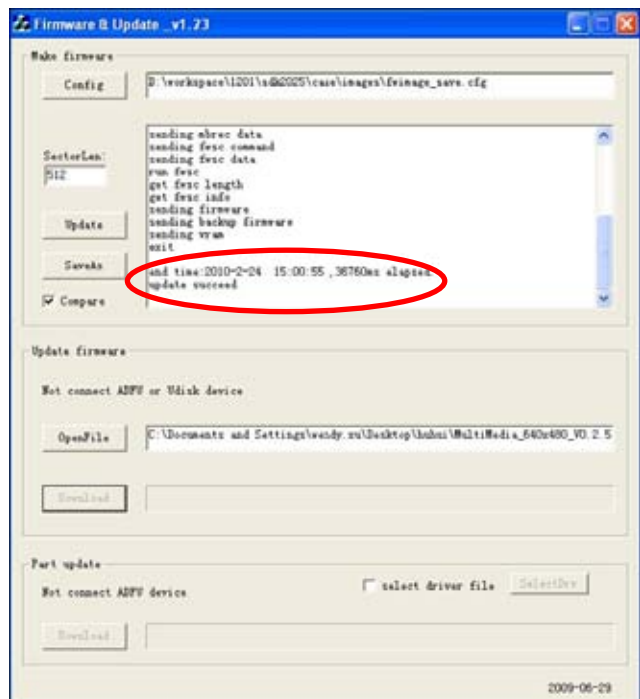

6. Restart the unit and enter the service mode to check the Multi-Media firmware version.

(To enter service mode, please refer to Chapter 4 Function Test and Alignment Procedure.)

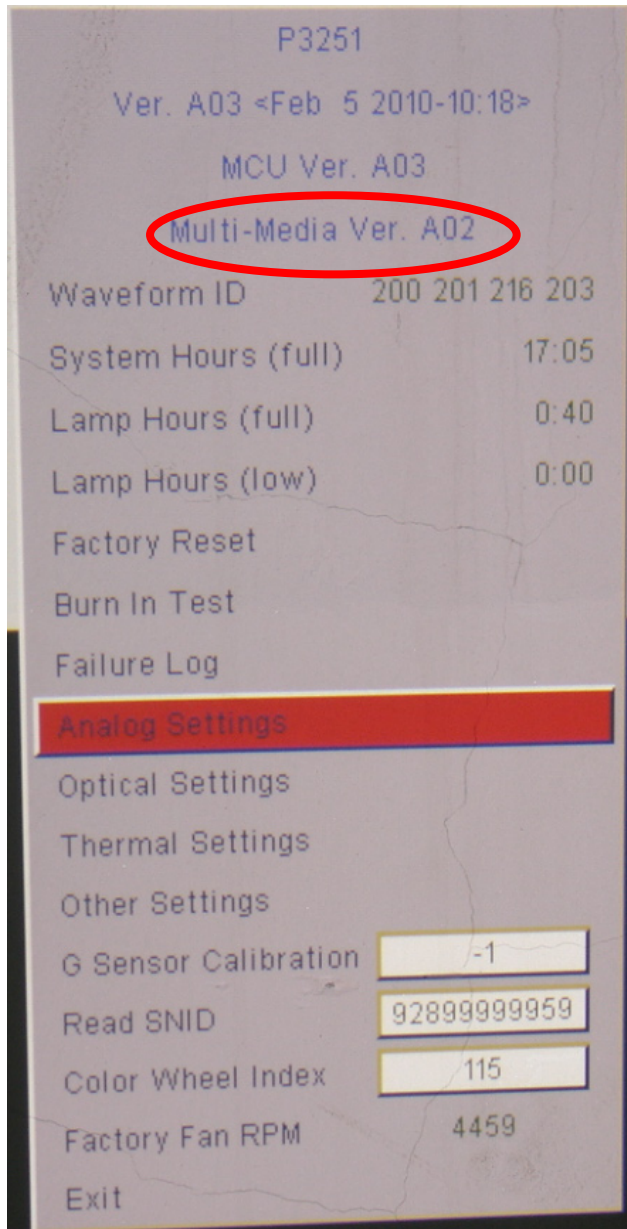

EDID Upgrade

6-1 EDID Introduction

Extended Display Identification Data is a VESA standard data format that contains basic information about a display device and its capabilities, including vendor information, maximum image size, color characteristics, factory pre-set timings, frequency range limits, and character strings for the monitor name and serial number.

The information is stored in the display and is used to communicate with the system through a Display Data Channel (DDC), which sits between the display device and the PC graphics adapter. The system uses this information for configuration purposes, so the monitor and system can work together.

Note: If a display device has digital input ports, like DVI or HDMI, but without EDID in its main board, the display device will show no image while the input source is digital signal. After EDID upgraded, do " default language reset"

6-2 Equipment Needed

Software

- EDID Program (Generic V0.51)
- EDID File

Hardware

- Projector
- Generic Fixture (80.00001.001) for EDID Key-in (Fixture: JP3 must be closed)
- Power cord for Projector (42.53506G002)
- RS-232 9 Pin Cable (pin to pin, F-M) (42.83C07G001)
- Monitor
- PC
- VGA cable (42.87305G102)
- DVI Cable (42.83N06G001)
- Power adapter (47.57803G001) and power cord (42.53506G002) for fixture
- Adapter HDMI(M) to DVI-D(F) (42.82B13G001)

Note: The EDID upgrade procedure for P3150/P3250/P3150 refresh/P3250 refresh/P3251 is the same. Here, we take P3250 as an example.

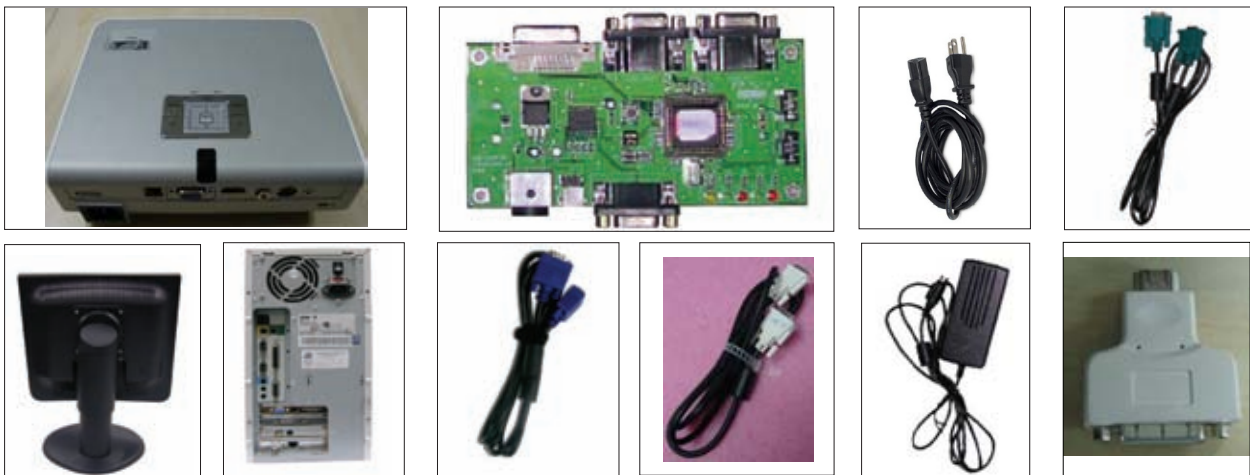

6-3 Setup Procedure (VGA)

1. Connect all ports
 - (1) Connect P1 of Fixture with COM Port of PC/Laptop by RS232 Cable.
 - (2) Connect P2 of Fixture with VGA port of Projector by VGA Cable.
 - (3) Plug Power Adapter to Power CNN.
 - (4) Plug Power Cord to P3250 unit.

Note: Confirm JP3 is Close status.

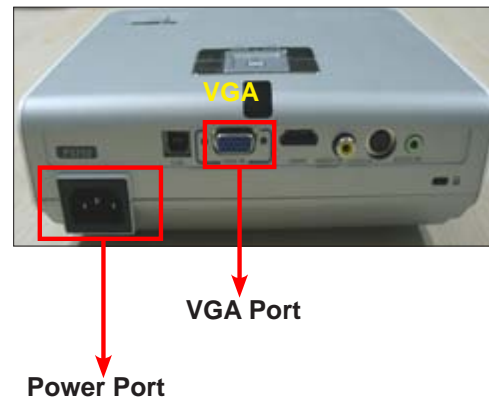
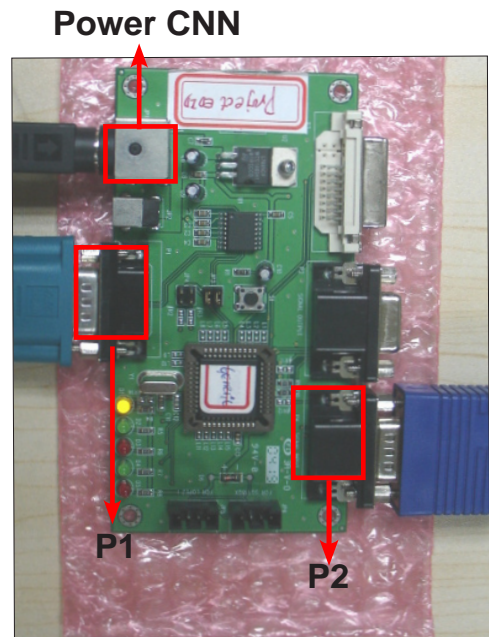

6-4 EDID Key-In Procedure

1. Execute EDID Program

- (1) Click on "EDID" to execute EDID program.

2. Process

- (1) Check the COM port is COM 1"
(Select the COM port which you are using).

- (2) Click the Model button.

- (3) Choose the source file
"ACER_P3250_20080218_C.ini"
and then open it.

3. Process

- (1) Key in the serial number into the barcode blank space.
- (2) In Write Source Select item, select Analog.
- (3) Click "Program" button.

4. Process

- (1) "Please change the cable to Analog" will be shown on the screen.
- (2) Please press "Ok" button.

1



2

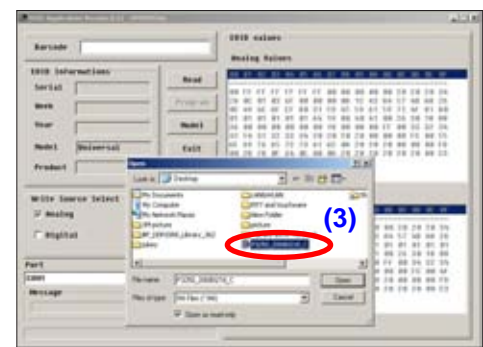
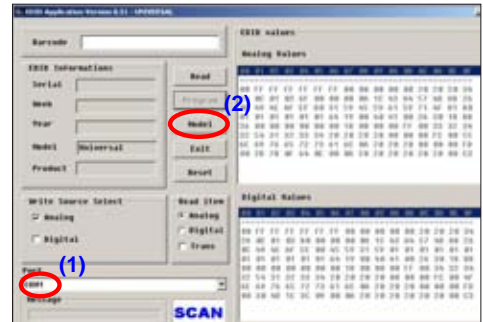

3

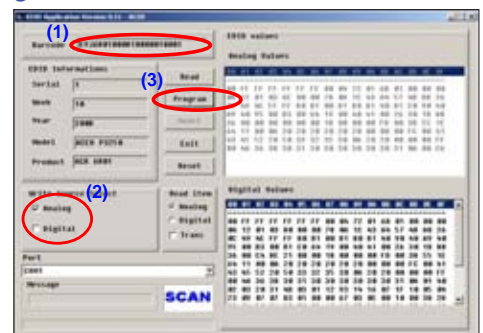

4

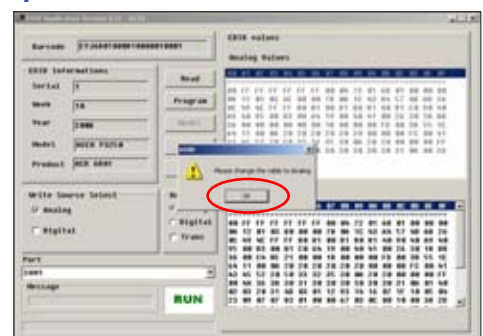

5. Finish

(1) "OK" will be shown on the screen.

6. Read EDID information

(1) In the Read item,select "Analog" and "Trans".

(2) Please press "Read" button.

7. Read EDID information

(1) EDID Informations will show the result.

5

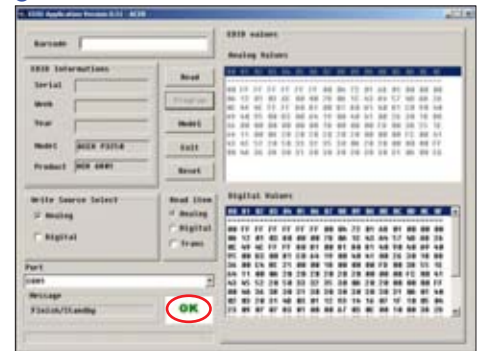

6

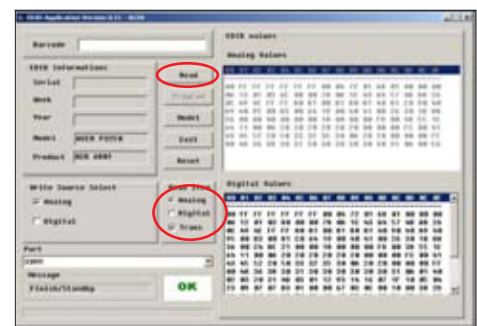

7

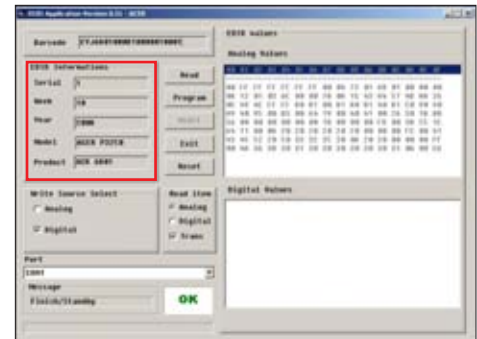

6-5 Setup Procedure (HDMI)

1. Connect all ports

- (1) Connect P1 of Fixture with COM Port of PC/Laptop by RS232 Cable.
- (2) Connect P2 of Fixture with P3 by DVI Cable.
- (3) Plug P4 to HDMI Port of the Projector.
- (4) Plug Power Adapter to Power CNN.
- (5) Plug Power Cord to P3250 unit.

Note: Confirm JP3 is Close status.



HDMI Port

Power Port

Power CNN

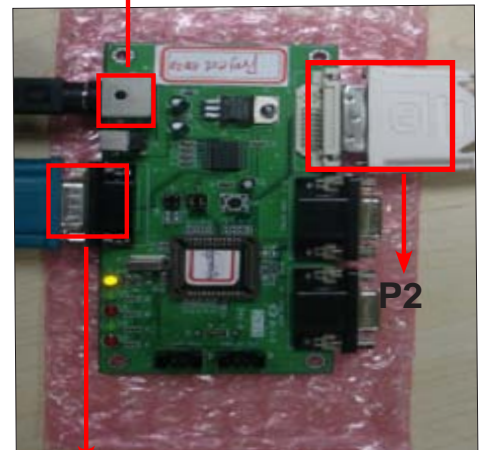

P1

P4

P2



P3

2. Process

- (1) Check the COM port is "COM 1"
(Select the COM port which you are using).
- (2) Click the "Model" button.
- (3) Choose the source file
"ACER_P3250_20080218_C.ini"
and then open it.

2

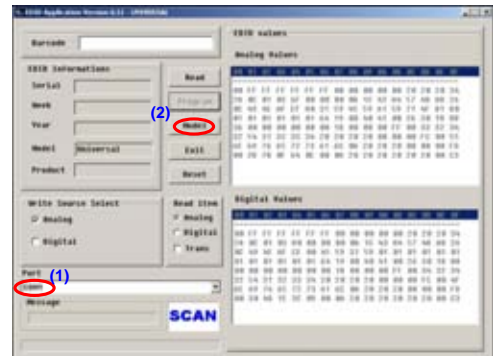

3. Process

- (1) Key in the serial number into the barcode blank space.
- (2) In "Write Source Select" item, select "Digital".

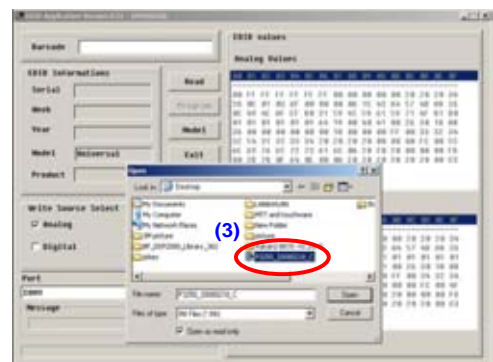

4. Process

- (1) "Please change the cable to Digital" will be shown on the screen.
- (2) Please press "Ok" button.

3

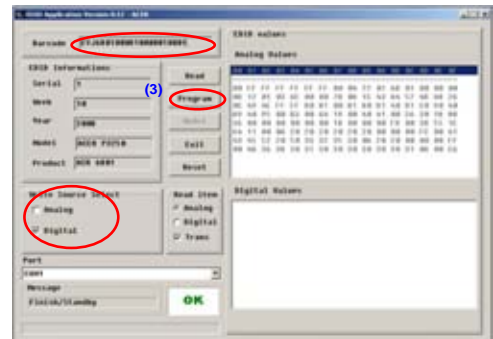

4

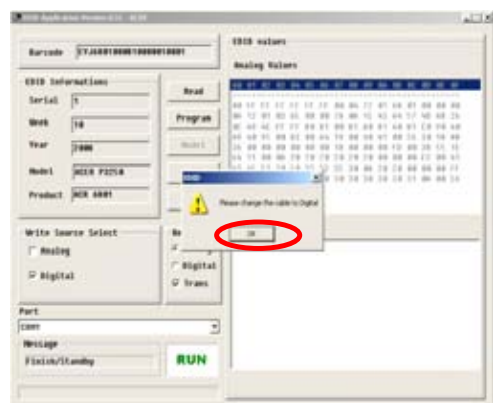

5. Finish

(1) "OK" will be shown on the screen.

6. Read EDID information

(1) In the Read item, select "Digital" and "Trans".

(2) Please press "Read" button.

7. Read EDID information

(1) EDID Informations will show the result.

5

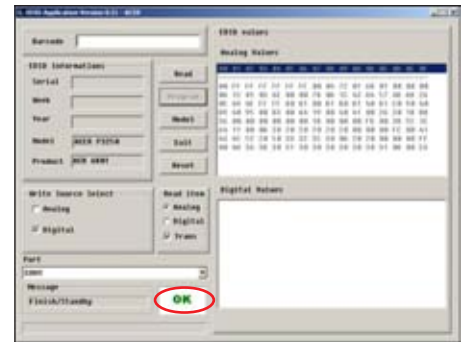

6

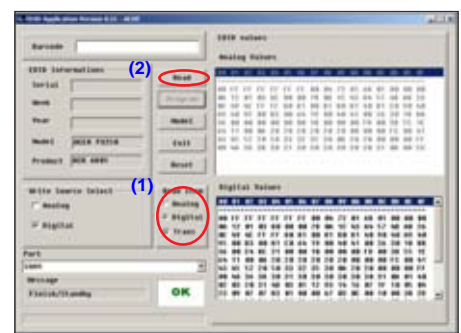

7

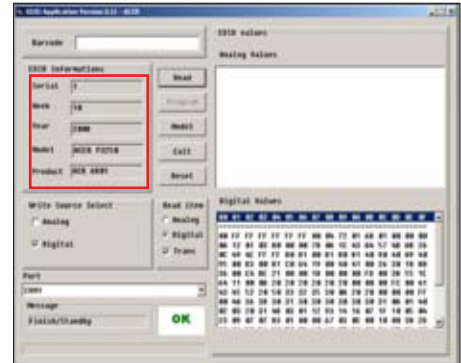

6-6 Default Language Reset (For P3150 refresh/P3250 refresh)

(1) Hold on “Down” button then plug in the Power Cord.

Note: At this moment, Power LED turns blue while Temp LED flashes in red for about 4s, then release the “Down” button.

(2) After that, please check the LED status and judge the actions as the following table:

LED Status	Result
Power(blue)+TEMP(red)+LAMP(red)	OK
Power(blue)+TEMP(red)	Fail

Note: if fail, please do the actions as above steps item (1)-(2)

S/N General rule



Use the last 1 digit code (as red word) for language information

Language code(F)	Default Language
1	English
2	Thailand
3	Japan
4	TC
5	SC
6	Russian
7	Germany
8	Hungarian

Appendix A

DC. P3150

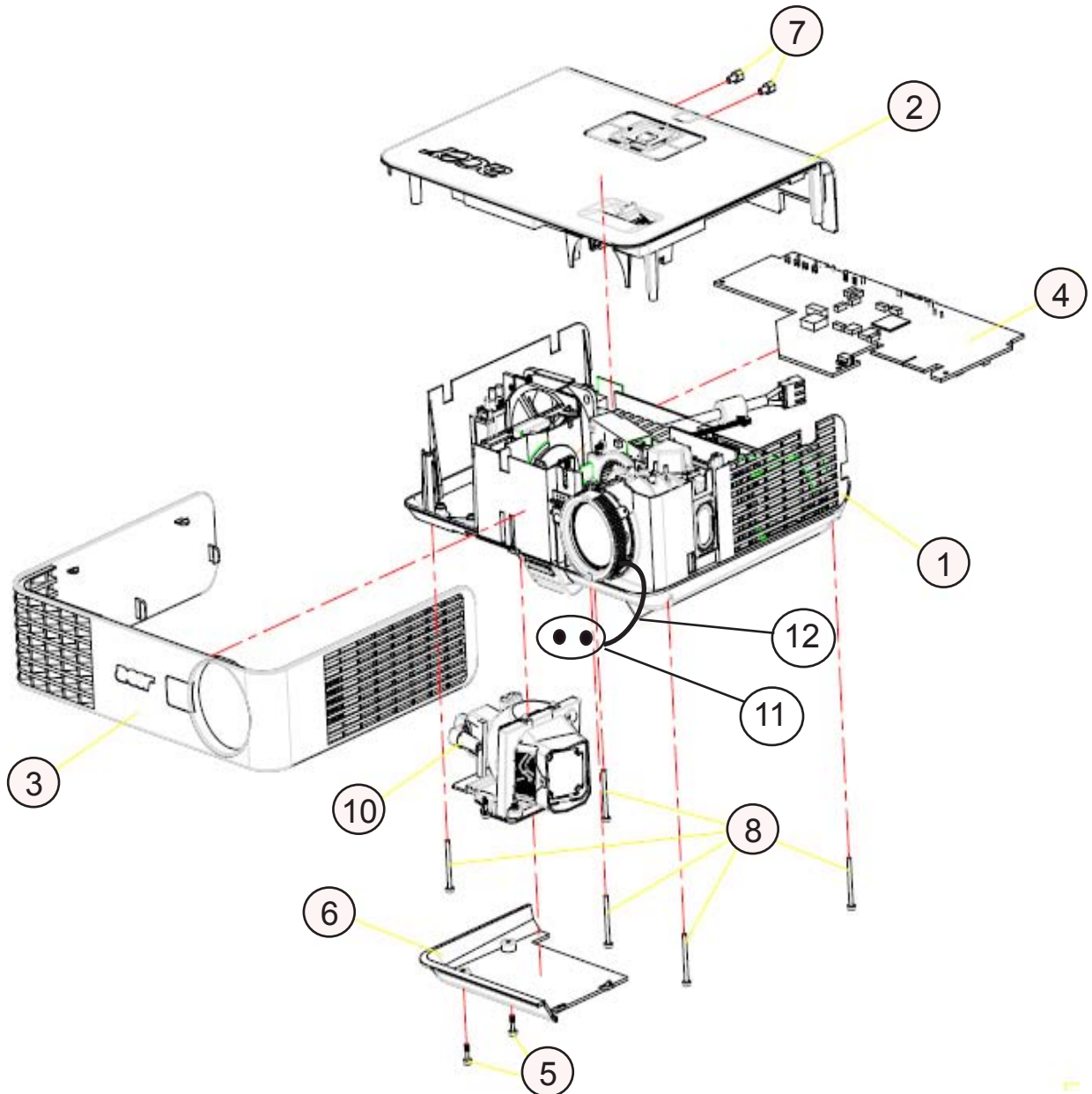

ITEM	P/N	DESCRIPTION	Supply
1	70.89Y03G001	ASSY BOTTOM COVER P3150	N
2	70.89Y01G001	ASSY TOP COVER MODULE P3150	N
3	70.89Y02G001	ASSY FRONT COVER P3150	N
4	70.89Y08G001	ASSY MAIN BOARD MODULE P3150	N
5	61.85928G001	LAMP HOUSING SHOULDER SCREW SB	N
6	51.89Y02G002	LAMP COVER P3150	
7	85.005AG040	SCREW I/O STEEL #4-40UNC*H4*L5	N
8	85.1A326G250	SCREW PAN MECH M2.6*25 BLACK	N
9	51.00001G001	CABLE TIE PG-YJ-80	N
	SP.89Y01GC01	LAMP MODULE FOR PROJECTOR P3150/ P3250	
10	70.89Y14G001	ASSY LAMP MODULE P3150	N
11	52.89Y04G002	LENS-CAP FOR P3150	
12	51.89Y16G001	LENS CAP STRAP P3150	

ASSY BLOWER 4510 MODULE

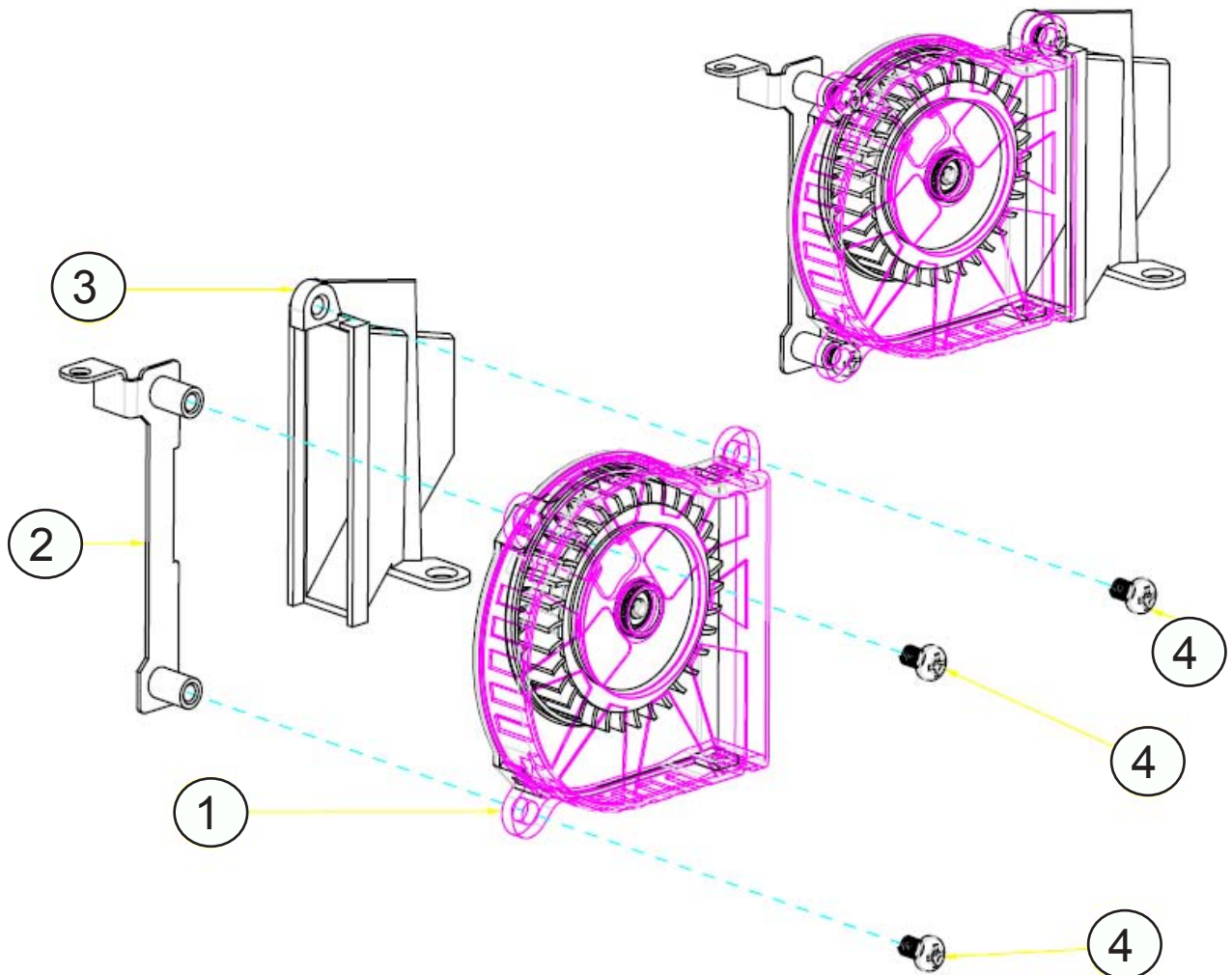

ITEM	P/N	DESCRIPTION	Supply
1	49.89S01G001	LAMP BLOWER / 45*45*10 mm, 60m	
2	61.89S13G001	BLOWER 4510 HOLDER SECC M209X	N
3	61.89S11G001	LAMP BLOWER 4510 DUCT AL M209X	N
4	85.1A126G040	SCREW PAN MECH M2.6*4 Ni	N

ASSY TOP COVER MODULE P3150

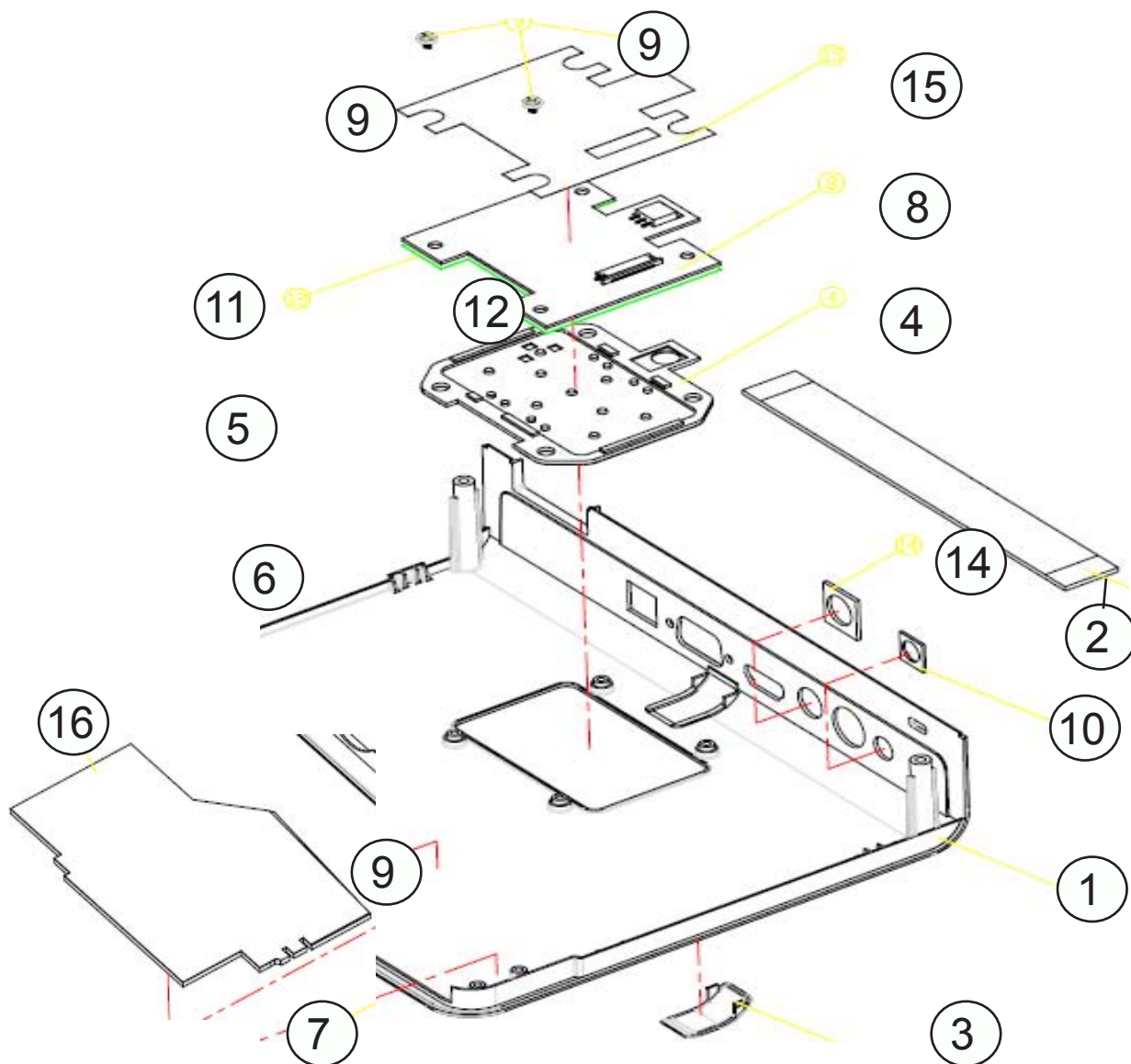

ITEM	P/N	DESCRIPTION	Supply
	70.89Y25GR01	ASSY TOP COVER MODULE FOR P3150(SERVICE)	
1	61.89Y02G001	TOP COVER P3150	N
2	42.89501G002	CABLE FPC 24P P=0.5 150mm KE	
3	51.89Y04G001	TOP IR LENS P3150	N
4	51.89Y11G002	KEYPAD BUTTON P+R P3150	
5	51.89Y06G001	ZOOM RING HOLDER P3150	N
6	51.89Y07G002	ZOOM RING P3150	
7	51.89Y12G001	TOP COVER PILLAR P3150	N
8	80.89Y03G001	PCBA KEYPAD BD FOR P3150	
9	85.1D122G030	SCREW PAN MECH M2*3 Ni(W/WSHER	N
10	41.87W02G001	EMI I/O GASKET (S-VIDEO /RS232	N
11	41.89Y02G001	EMI GASKET W8*H1*L30	N
12	51.89Y13G001	METAL DOME P3150	N
13	41.87W02G001	EMI I/O GASKET (S-VIDEO /RS232	N
14	41.83M11G001	S-VIDEO GASKET 2400MP	N
15	51.89Y15G001	KEYPAD TAPE P3150	N
16	52.89Y06G001	FRAME AL FOIL/F12 LAMP P3150	N

ASSY FRONT COVER P3150

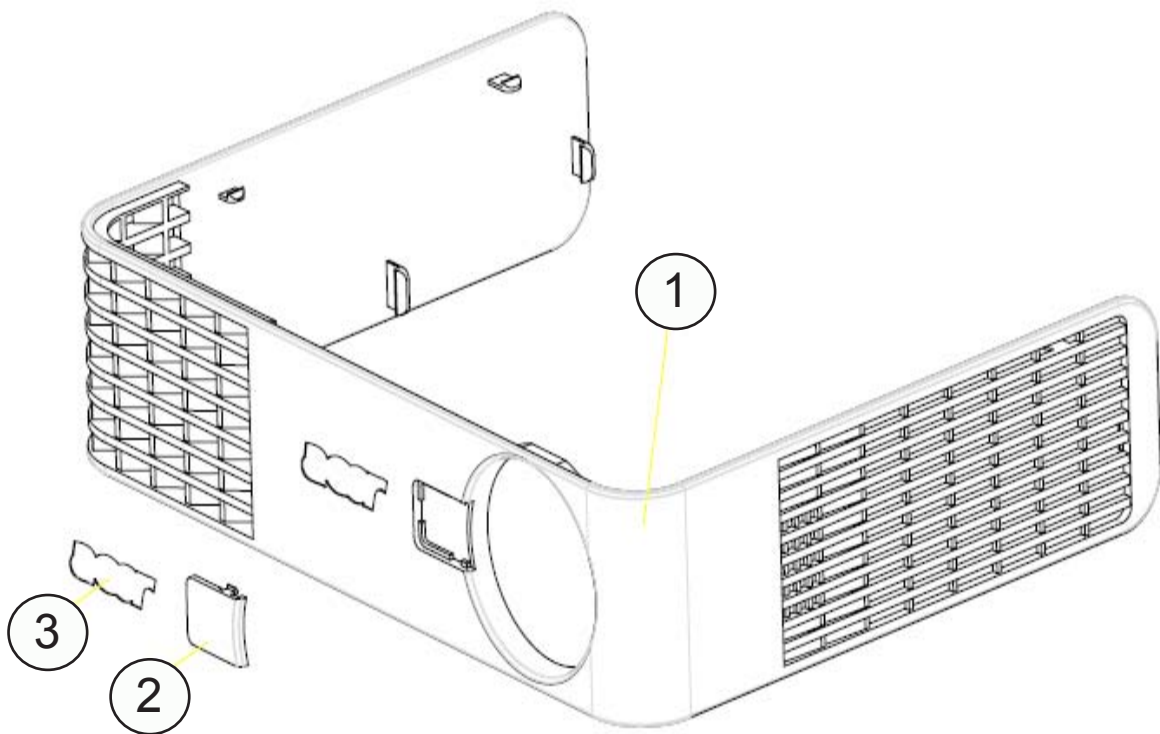

ITEM	P/N	DECRPTION	Supply
	70.89Y24GR01	ASSY FRONT COVER MODULE FOR P3150/P3250(SERVICE)	
1	51.89Y01G001	FRONT COVER P3150	N
2	51.89Y03G001	FRONT IR LENS P3150	N
3	61.88T15G001	ACER LOGO FOR X1160	

ASSY BOTTOM COVER P3150

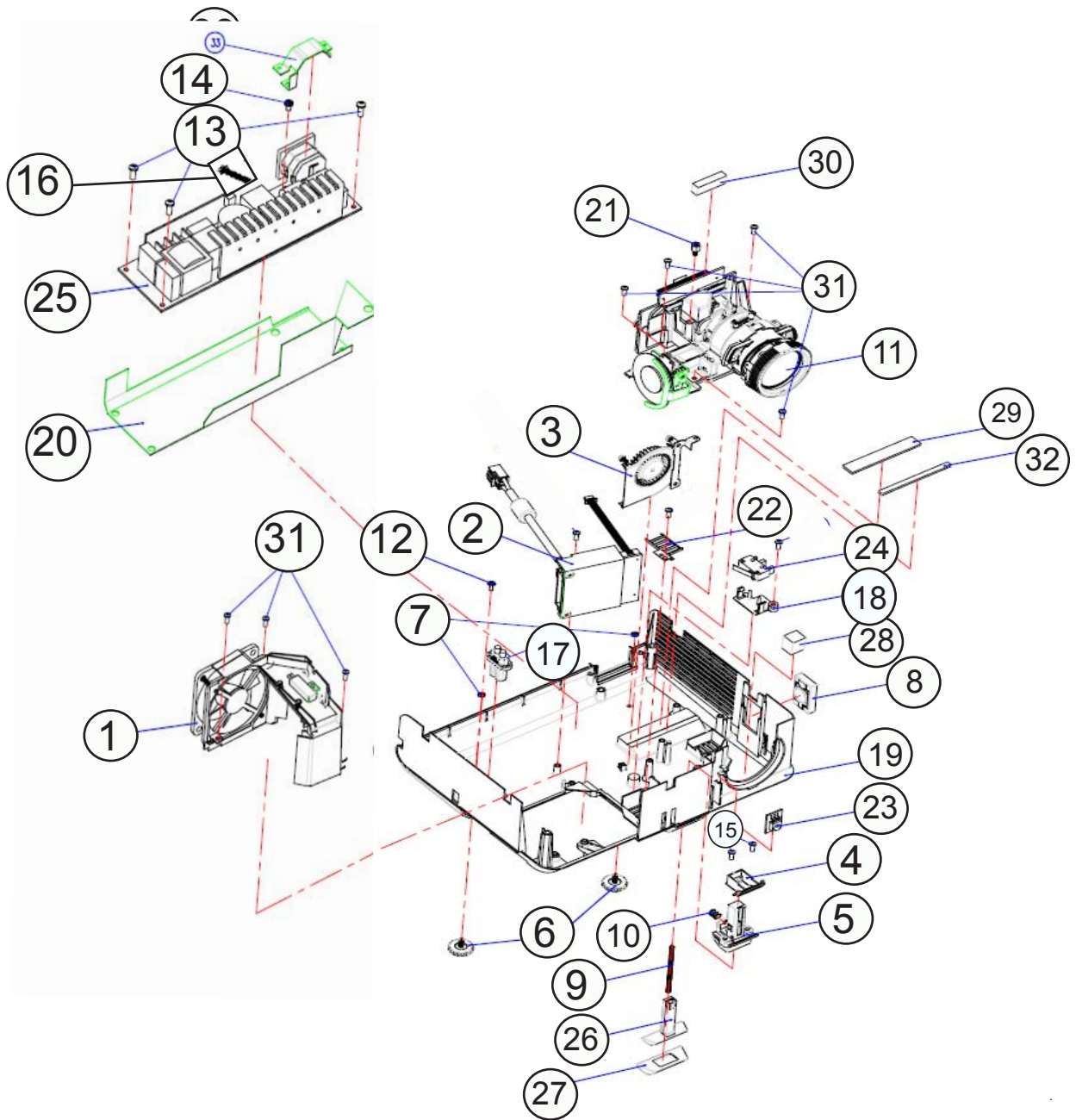

ITEM	P/N	DESCRIPTION	Supply
1	70.89Y17G001	ASSY LAMP HOUSING MODULE M209X	N
2	70.89Y13G001	ASSY DC-DC MODULE P3150	N
3	70.89S09G001	ASSY BLOWER 4510 MODULE M209X	N
4	51.89Y08G001	ELEVATOR PUSH BUTTON P3150	
5	51.89Y09G001	ELEVATOR BASE P3150	N
6	52.89Y02G001	ADJUST FOOT P3150	N
7	86.00122G015	NUT HEX M2.0*0.4P L15 Ni	N
8	70.89Y06G001	ASSY SPEAKER MODULE P3150	N
9	61.89S20G001	ELEVATOR BASE SPRING M209X	N
10	61.89S21G001	ELEVATOR PUSH SPRING M209X	N
11	70.89Y04G001	ASSY OPTICAL ENGINE MODULE P31	N
12	85.1D122G030	SCREW PAN MECH M2*3 Ni(W/WSHER	N
13	85.1A123G060	SCREW PAN MECH M3*6 NI	N
14	85.1C224G051	SCREW PAN MECH M4*5 COLOR W/TO	N
15	85.1A126G040	SCREW PAN MECH M2.6*4 Ni	N
16	42.00472G001	W.A. 5P #28 140MM MAIN BOARD/B	
17	42.00491G001	W.A. 2P #22 FEMALE 6KV 150 75	N
18	51.89S18G001	INTERLOCK SWITCH HOLDER PC M20	N
	70.89Y26GR01	ASSY BOTTOM COVER MODULE FOR P3150/P3250 (SERVICE)	
19	61.89Y01G001	BASE COVER P3150	N
20	51.89Y14G001	BALLAST MYLAR P3150	N
21	61.89S24G001	MAIN BOARD STAND-OFF M2.6X4.0m	N
22	61.89S25G001	COLOR WHEEL VENT SUS304 M209X	N
23	80.89S05G001	PCBA IR SENSOR BD FOR M209X	
24	75.89S06G002	NEW BUY ASSY INTERLOCK SWITCH	
25	70.89Y27GR01	ASSY OSRAM BALLAST FOR P3150/P3250 (SERVICE)	
26	51.89Y10G001	ELEVATOR SUPPORT P3150	N
27	52.89Y03G002	ELEVATOR FOOT P3150	
28	41.89S01G001	EMI GASKET W10*H13*L12	N
29	41.89Y01G001	EMI GASKET W10*H3*L55	N
30	41.89S05G001	EMI GASKET W6.5*H12*L30	N
31	85.1A326G060	SCREW PAN HEAD MECH M2.6*6 BLA	N
32	52.89Y05G001	DMD BOTTOM-SIDE THERMAL PAD GR	N
33	61.89Y03G001	AC INLET BRACKET P3150	

ASSY MAIN BOARD MODULE P3150

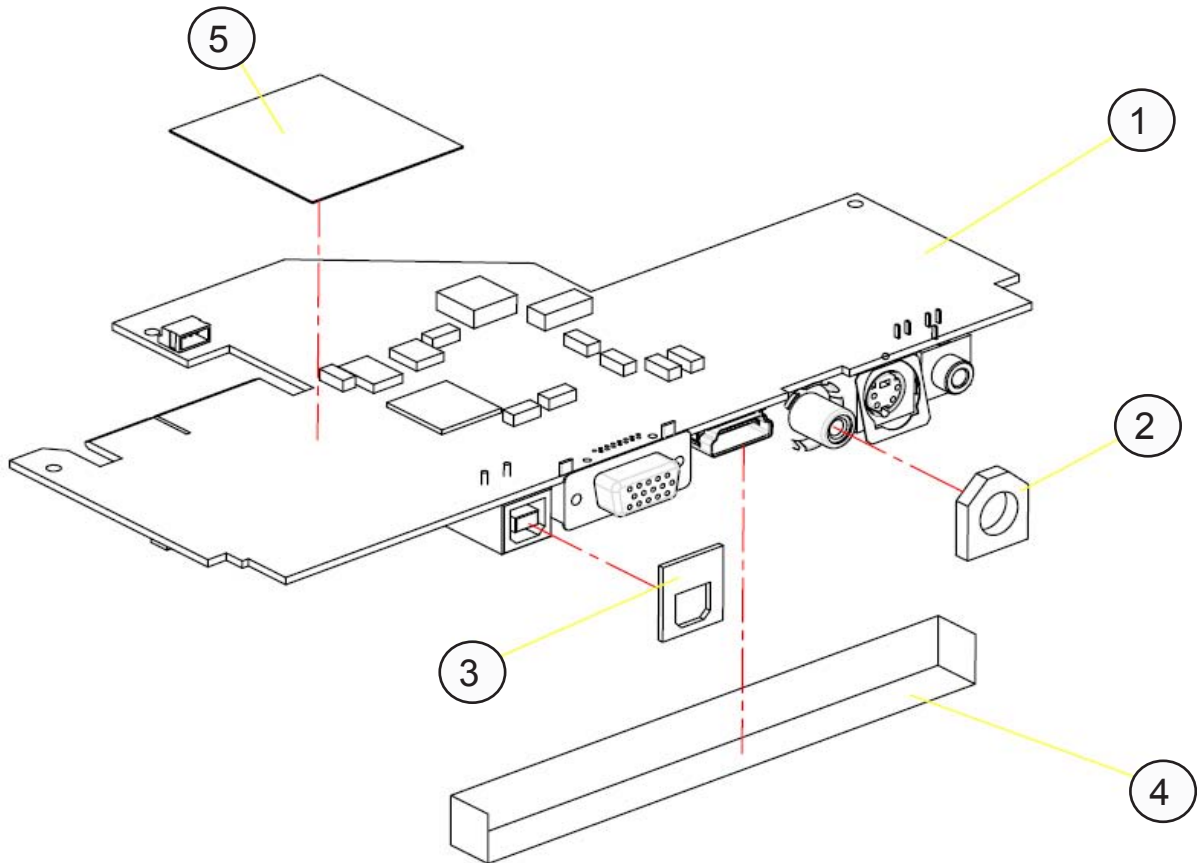

ITEM	P/N	DESCRIPTION	Supply
	70.89Y23GR01	ASSY PCBA MAIN BD MODULE FOR P3150(SERVICE)	
1	80.89Y01G001	PCBA MAIN BOARD FOR P3150	N
2	41.82B17G001	EMI VIDEO GASKET	N
3	41.82G03G001	EMI GASKET USB CONNECTOR EP719	N
4	41.89S14G001	EMI TAPE W30*L30	N
5	51.89Y17G001	MAIN BOARD LIGHTCUT MYLAR P315	N

ASSY DC-DC MODULE P3150

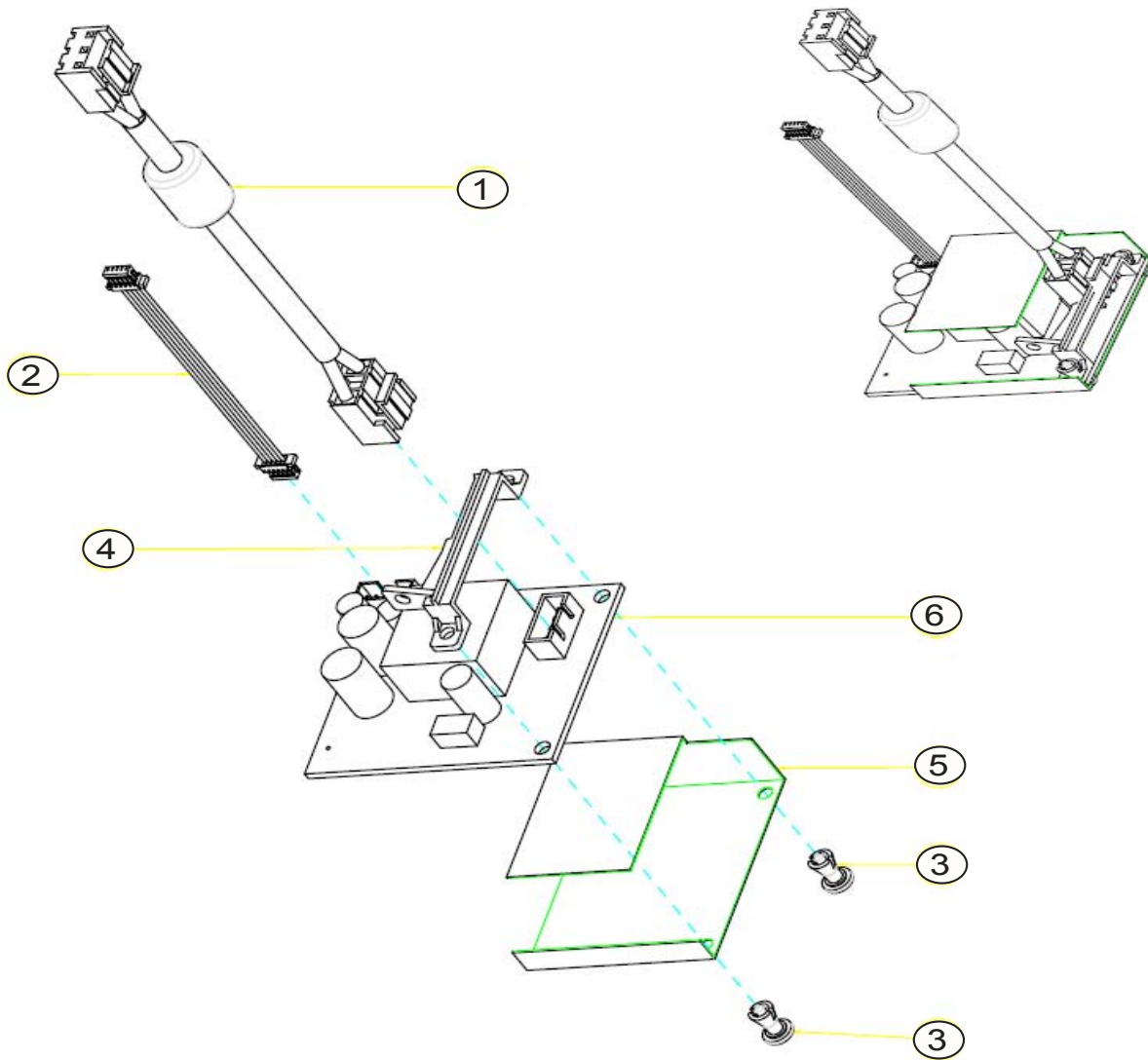

ITEM	P/N	DESCRIPTION	Supply
	70.89Y28GR01	ASSY DC-DC MODULE FOR P3150/P3250 (SERVICE)	
1	42.004A1G001	W.A.4P #24/#26 100mm DC.DC/BALLAST	
2	42.004B1G001	W.A. 5P #26 140mm DC-DC/MAIN BOARD M209X	
3	51.00061G001	PLASTIC RIVET E3.0 SR-3L "A0"	N
4	51.89S17G001	DC HOLDER PC M209X	N
5	51.89S23G001	DC-DC MYLAR M209X	N
6	75.89S08G001	ASSY MATRITEK D2D M209P	N

ASSY LAMP HOUSING MODULE P3150

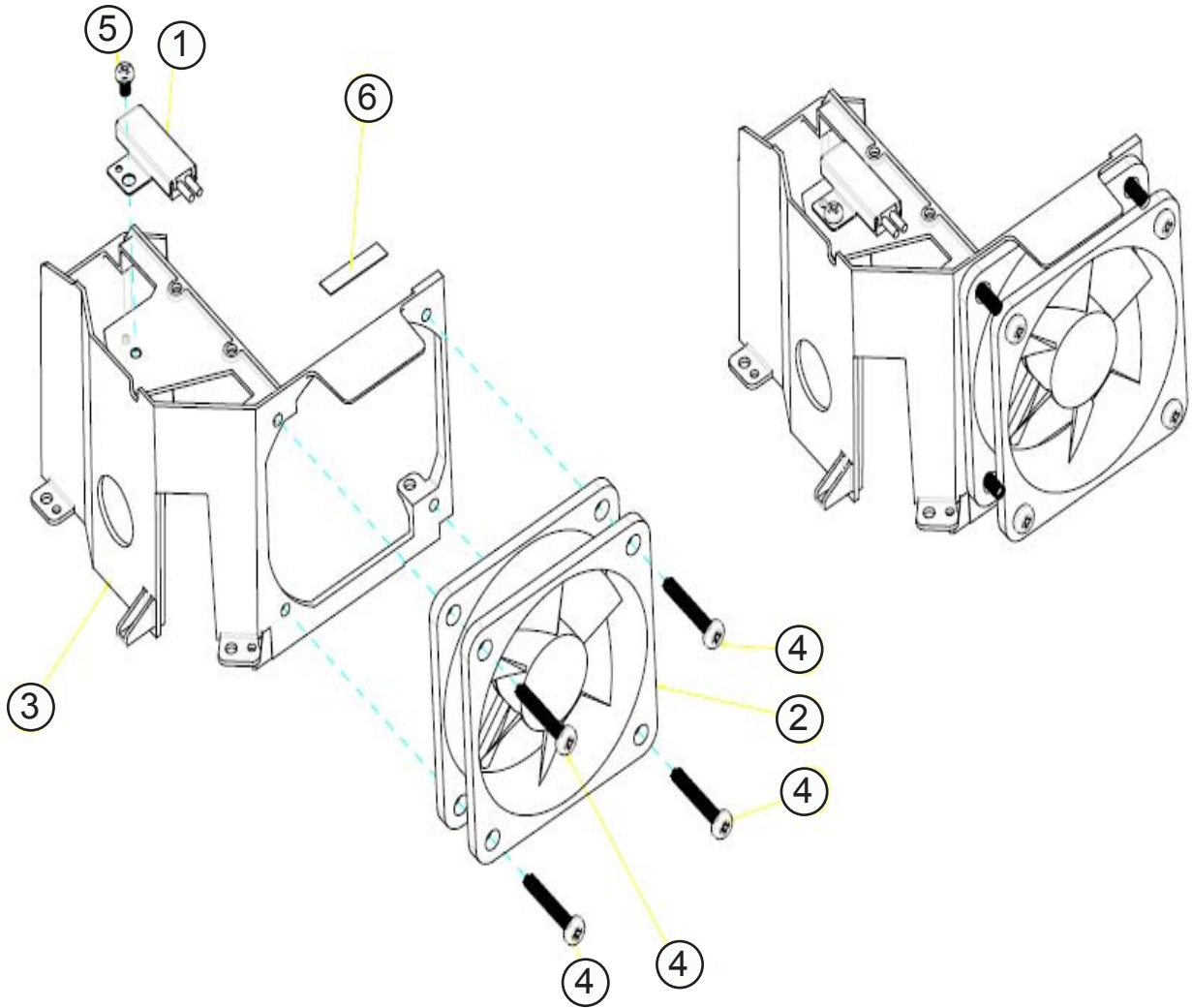

ITEM	P/N	DESCRIPTION	Supply
1	43.89S01G001	TH-RMAI SWITCH WITH BRACKET (KLIX-ON YSII)	
2	49.85M03G001	SYSTEM FAN/55*55*15mm	
3	61.89Z06G001	LAMP HOUSING MG ALLOY EX330	N
4	85.1A123G180	SCREW PAN MECH M3*18 NI EP910	N
5	85.1A126G040	SCREW PAN MECH M2.6*4 Ni	N
6	41.89S03G001	EMI TAPE W5*L25 H0.65	N

ASSY SPEAKER MODULE P3150

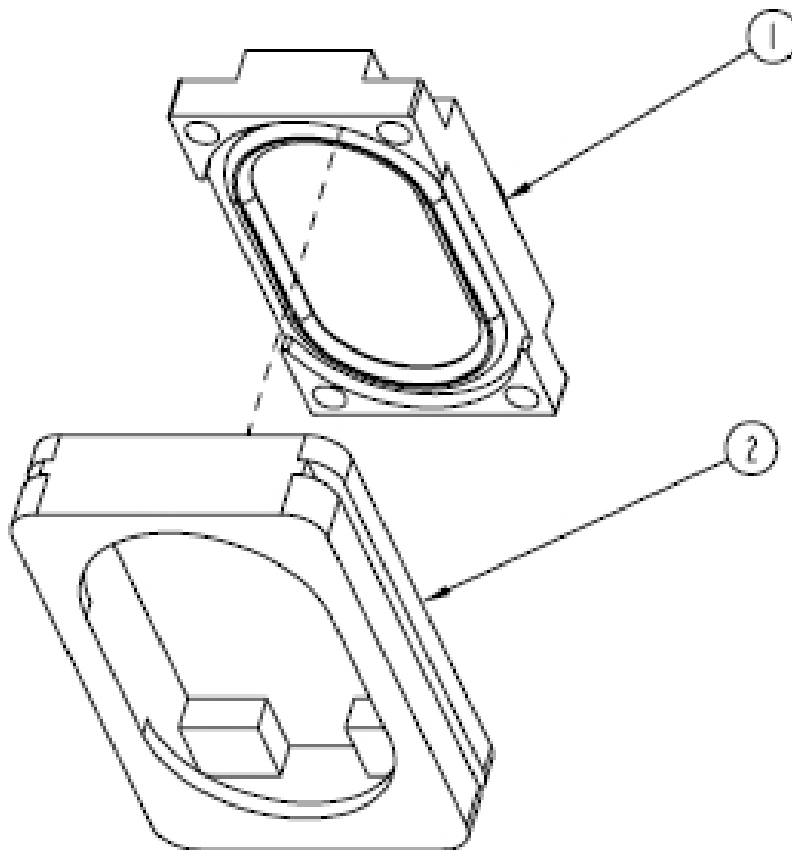

ITEM	P/N	DECRPTION	Supply
1	49.89Y01G001	SPEAKER MINI IW 4 ohm 140 mm P3150	
2	52.89Y01G001	SPEAKER RUBBER P3150	N

ASSY ENGINE MODULE P3150

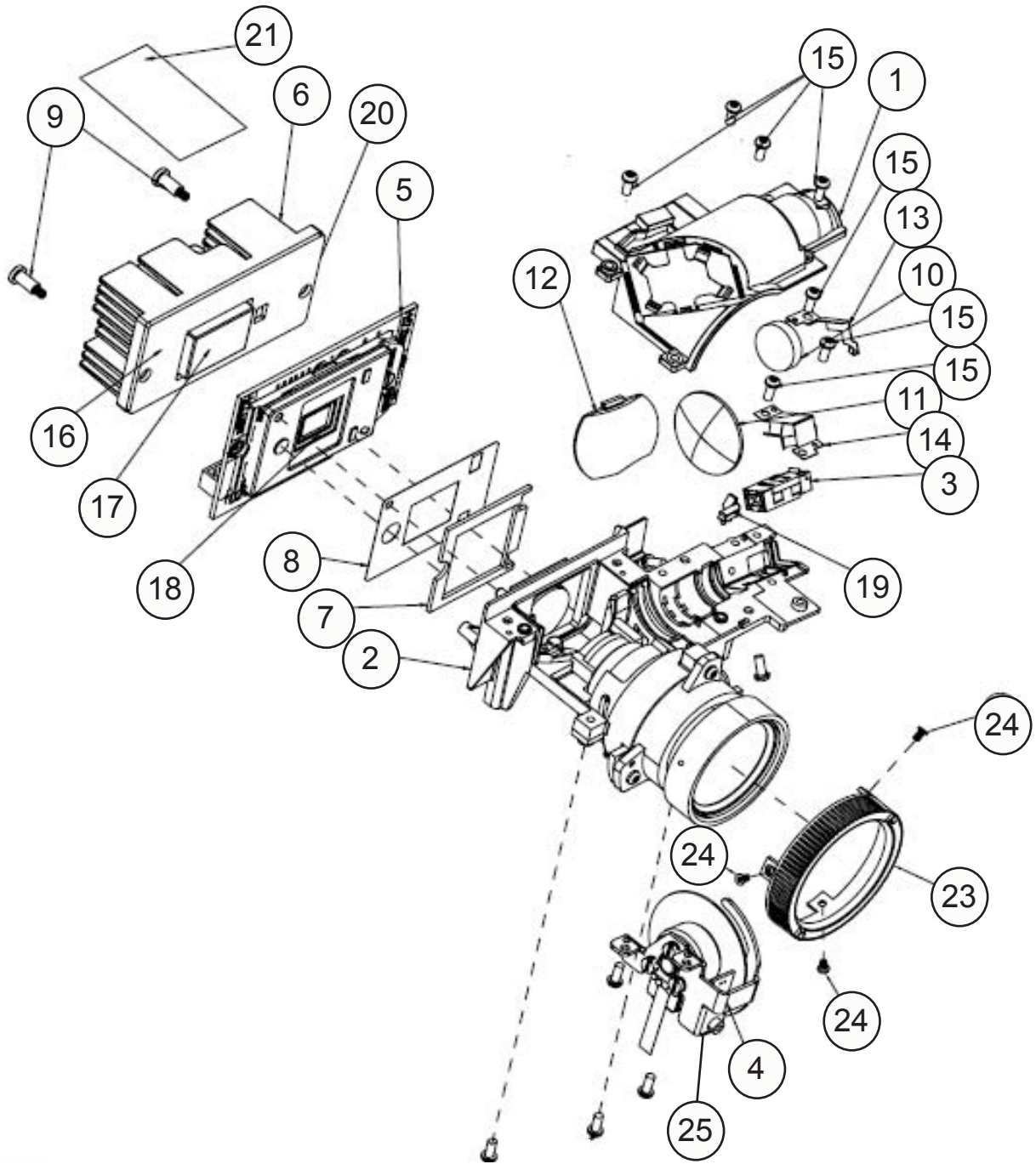

ITEM	P/N	DESCRIPTION	Supply
	70.89Y22GR01	ASSY ENGINE MODULE FOR P3150/ P3250(SERVICE)	
1	70.89Y15G001	ASSY ENGINE BOTTOM COVER P3150	N
2	70.89Y05G001	ASSY ENGINE BASE MODULE P3150	N
3	70.89Y16G001	ASSY ROD MODULE P3150	N
4	70.89Y21GR01	ASSY COLOR WHEEL MODULE P3150	
5	80.89S02G001	PCBA DMD BOARD FOR M209X	
6	61.89S10G001	DMD HEATSINK AL M209X	N
7	52.88N04G002	DMD RUBBER NEW 1.3T X15	N
8	61.88N15G001	DMD MASK,SUS301,X15	N
9	85.4A826G118	STEP SCREW FOR TYPEX DMD M2.6*11.8mm,X15	
10	23.88N20G001	YO CONDENSER1 FOR X15	N
11	23.88N20G011	YO CONDENSER2 FOR X15	N
12	23.88N06G011	YO PLASTIC RELAY FOR X15	N
13	61.88N13G002	ROD COVER NEW,SUS301,X15	N
14	61.88N12G001	ROD SPRING,SUS301,X15	N
15	85.1A526G060	SCREW PAN MECH M2.6*6 NI NYLOK	N
16	52.88N03G002	HEAT SINK RUBBER(X15) X1160	N
17	52.87J01G001	DMD THERMAL PAD 25*17*0.5t FUJIPOLY SAR- GON GR-Hn	
18	48.87K01G001	DMD Type-X 800x600 PIXEL 0.55"	
19	61.88N39G001	STOP MASK MG X15	N
20	61.89Y06G001	HEX SCREW M2.6*H6.8*L5, STEEL	N
21	41.82K09G001	EMI TAPE 30*50mm	N
22	85.0A126G040	SCREW DOUBLE FLAT MECH M2.6*4Ni	N
23	51.89Y05G001	FOCUS RING P3150	
24	85.WA321G040	SCREW PAN TAP M1.7*4 BLACK	N
25	80.88N04G001	PCBA PHOTO SENSOR BOARD FOR EP721	

AK. P3150

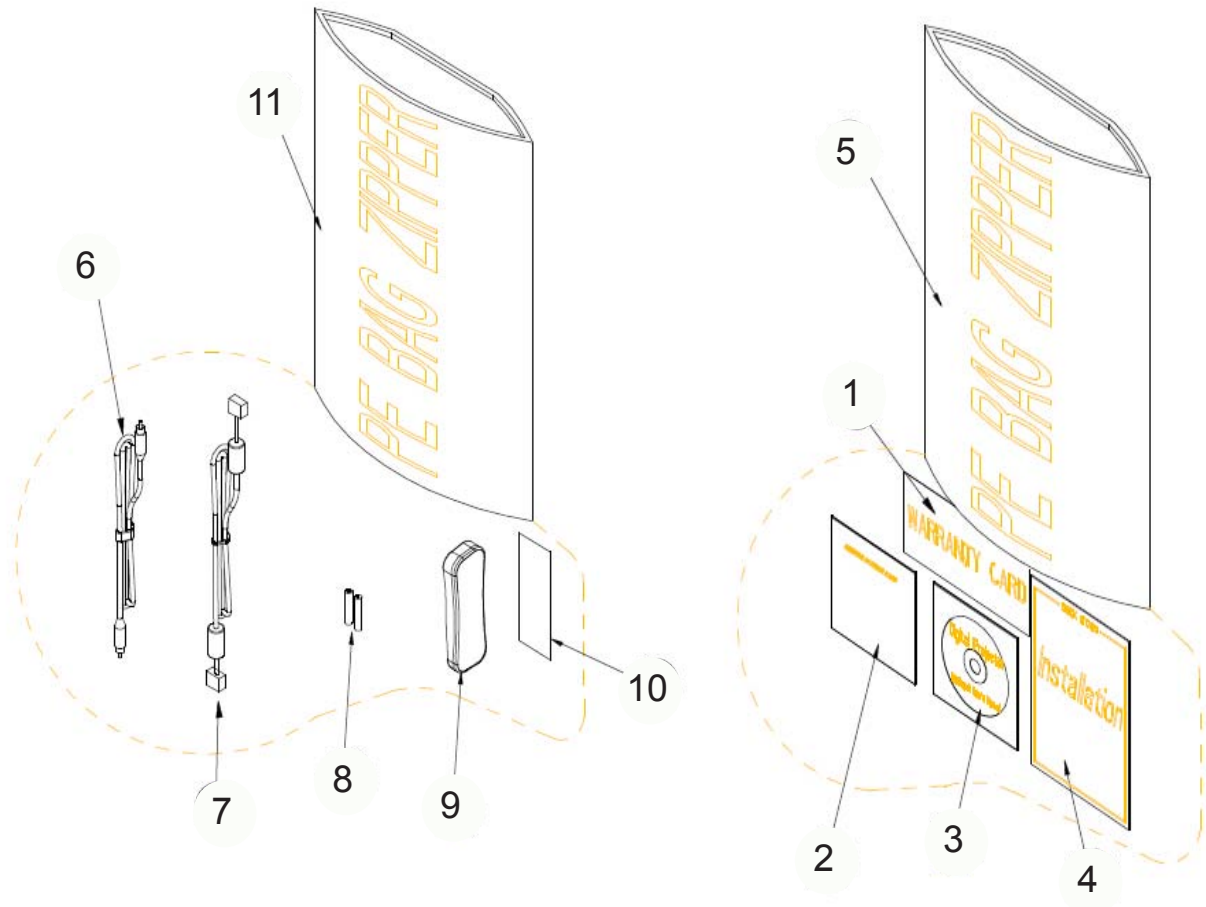

ITEM	P/N	DESCRIPTION	Supply
1	36.00006G031	WARRANTY CARD ,EUROPE FOR ACER	N
2	36.00027G001	SERVICE STATION CARD	N
3	36.89Y01G001	USER'S GUIDE MULTILINGUAL (C	N
4	36.89Y02G001	QUICK START CARD MULTILINGUA	N
5	51.86213G002	PE BAG ZIPPER #9 W/RECYCLING M	N
6	42.00232G001	CABLE COMPOSITE VIDEO 2M YELLO	N
7	42.83M09G101	CABLE MINI JACK TO MINI JACK	N
8	46.82V02G001	BATTERY #4 1.5V R04 PD120	N
9	45.87U01G106	INFRARED REMOTE CONTROLLER L	
10	36.00029G001	SECURITY CARD FOR ACER	N
11	51.86213G002	PE BAG ZIPPER #9 W/RECYCLING M	N

DP. P3150

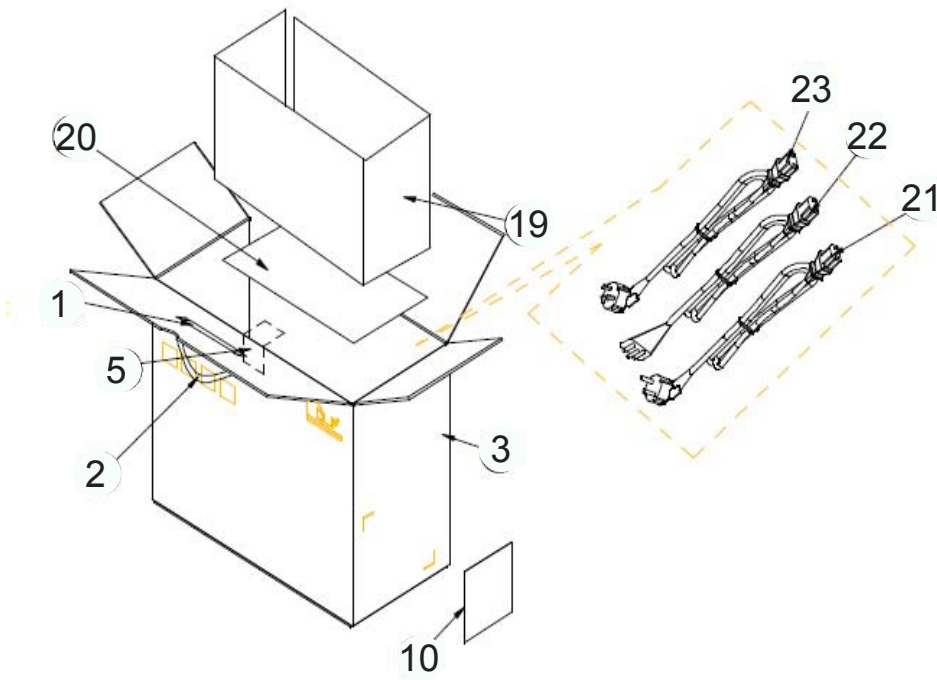
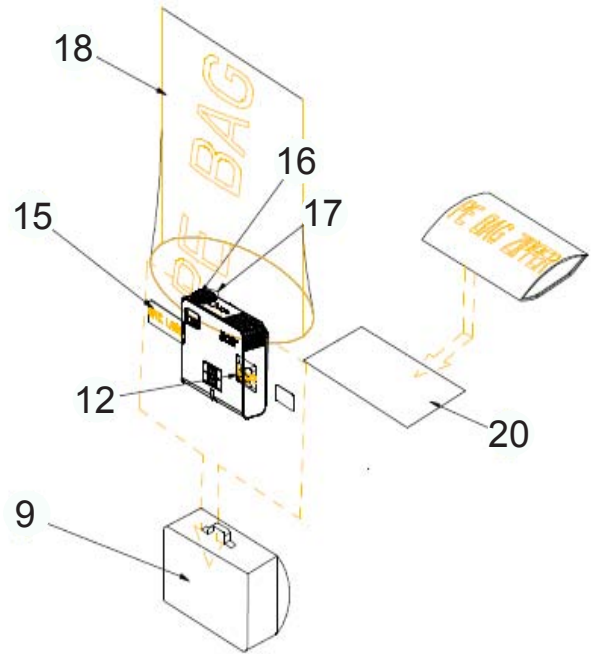

ITEM	P/N	DESCRIPTION	Supply
1	51.00201G001	HANDLE BAR 1.PE HD70	N
2	51.00200G001	HANDLE BAR 2. PE HD70	N
3	55.89Y01G001	CARTON CARRY BOX P3150	N
4	55.89Y02G001	CENTER PAPER BOX P3150	N
5	35.82L04G001	ACER TAPE 45M FOR CARTON	N
6	55.87W04G001	CORNER PAPER P5271	N
7	58.86202GC02	COVER PALLET 1150*970mm FOR 34	N
8	58.86201GC02	WOOD PALLET 48"*40*5"(DOUBLE F	N
9	53.89Y01G001	SOFT CARRY BAG P3150	N
10	35.52302G091	LABEL CARTON 108*92 BLANK	N
11	55.87202G001	BOTTOM PAPER COVER PLATE 1230*	N
12	57.00001G001	PACK SIO2 DRIER 20g	N
13	35.82L04G001	LAMP WARNING LABEL ARES A	N
14	35.82V02G001	LABEL CARTON(SEAL) 110*50mm PD	N
15	35.85M02G001	SPEC LABEL PD311	N
16	52.89Y04G002	LENS-CAP FOR P3150	N
17	51.89Y16G001	LENS CAP STRAP P3150	N
18	51.00174G002	PE BAG 380*310*0.07mm FOR OP	N
19	56.89Z01G001	AIR BAG RIM EX330	N
20	56.89Z02G001	AIR BAG TOP/BOTTOM EX330	N
21	42.00120G011	CABLE POWER CORD 1.8M SP-023/IS-14 EUROPE DIS-WARNING LABEL	
22	42.00110G011	CABLE POWER CORD 1.8M SP-60/IS-14 UK DIS-WARNING LABEL	
23	42.00131G011	CABLE POWER CORD 1.8M SP-027/IS-14 SWITZERLAND DIS-WARNING LABEL	

DC. P3250

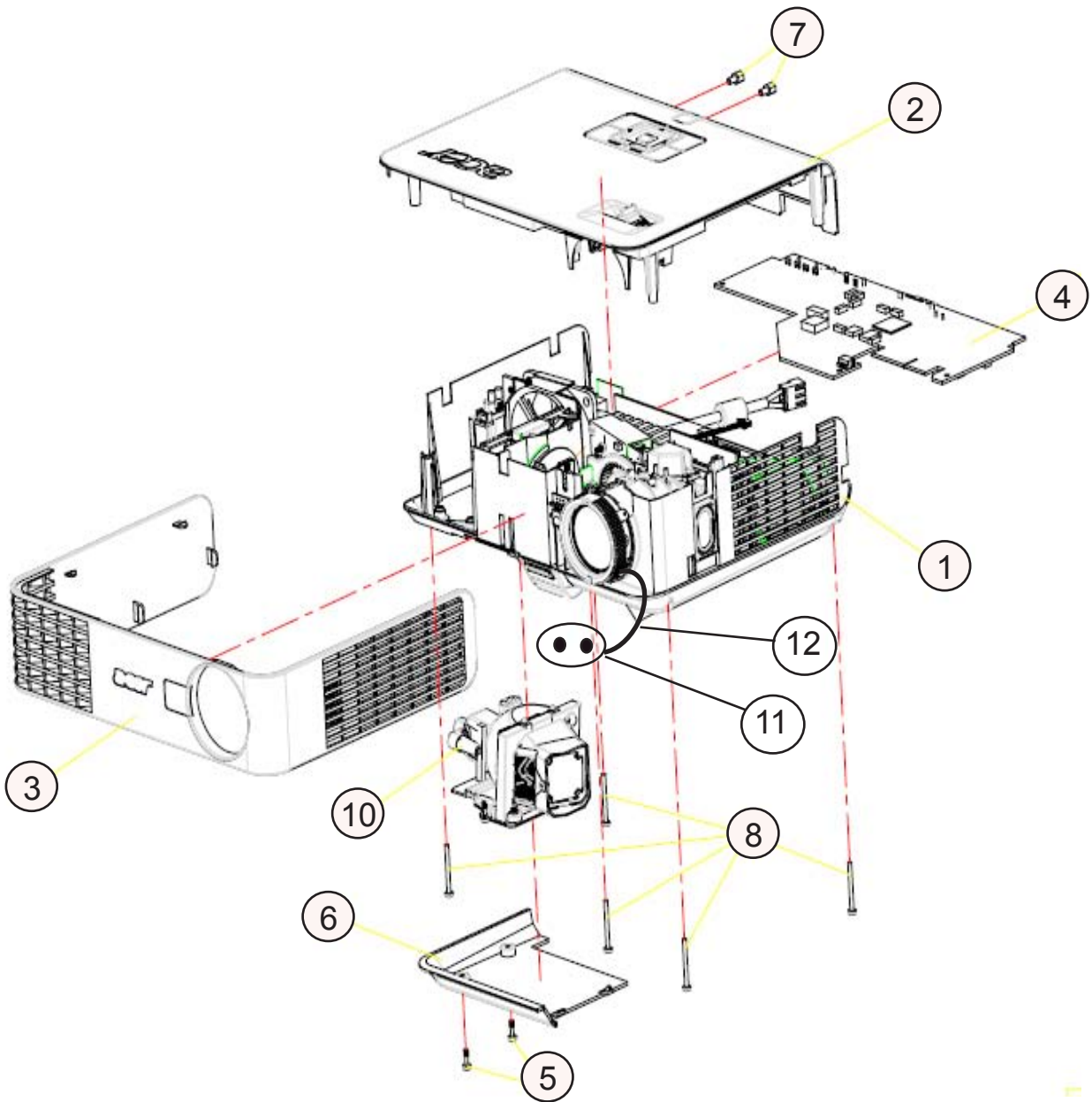

ITEM	P/N	DESCRIPTION	Supply
1	70.89Y03G001	ASSY BOTTOM COVER P3150	N
2	70.89Y01G001	ASSY TOP COVER MODULE P3150	N
3	70.89Y02G001	ASSY FRONT COVER P3150	N
4	70.89Y08G001	ASSY MAIN BOARD MODULE P3150	N
5	61.85928G001	LAMP HOUSING SHOULDER SCREW SB	N
6	51.89Y02G002	LAMP COVER P3150	
7	85.005AG040	SCREW I/O STEEL #4-40UNC*H4*L5	N
8	85.1A326G250	SCREW PAN MECH M2.6*25 BLACK	N
9	51.00001G001	CABLE TIE PG-YJ-80	N
	SP.89Y01GC01	LAMP MODULE FOR PROJECTOR P3150/ P3250	
10	70.89Y14G001	ASSY LAMP MODULE P3150	N
11	52.89Y04G002	LENS-CAP FOR P3150	
12	51.89Y16G001	LENS CAP STRAP P3150	

ASSY BLOWER 4510 MODULE P3250

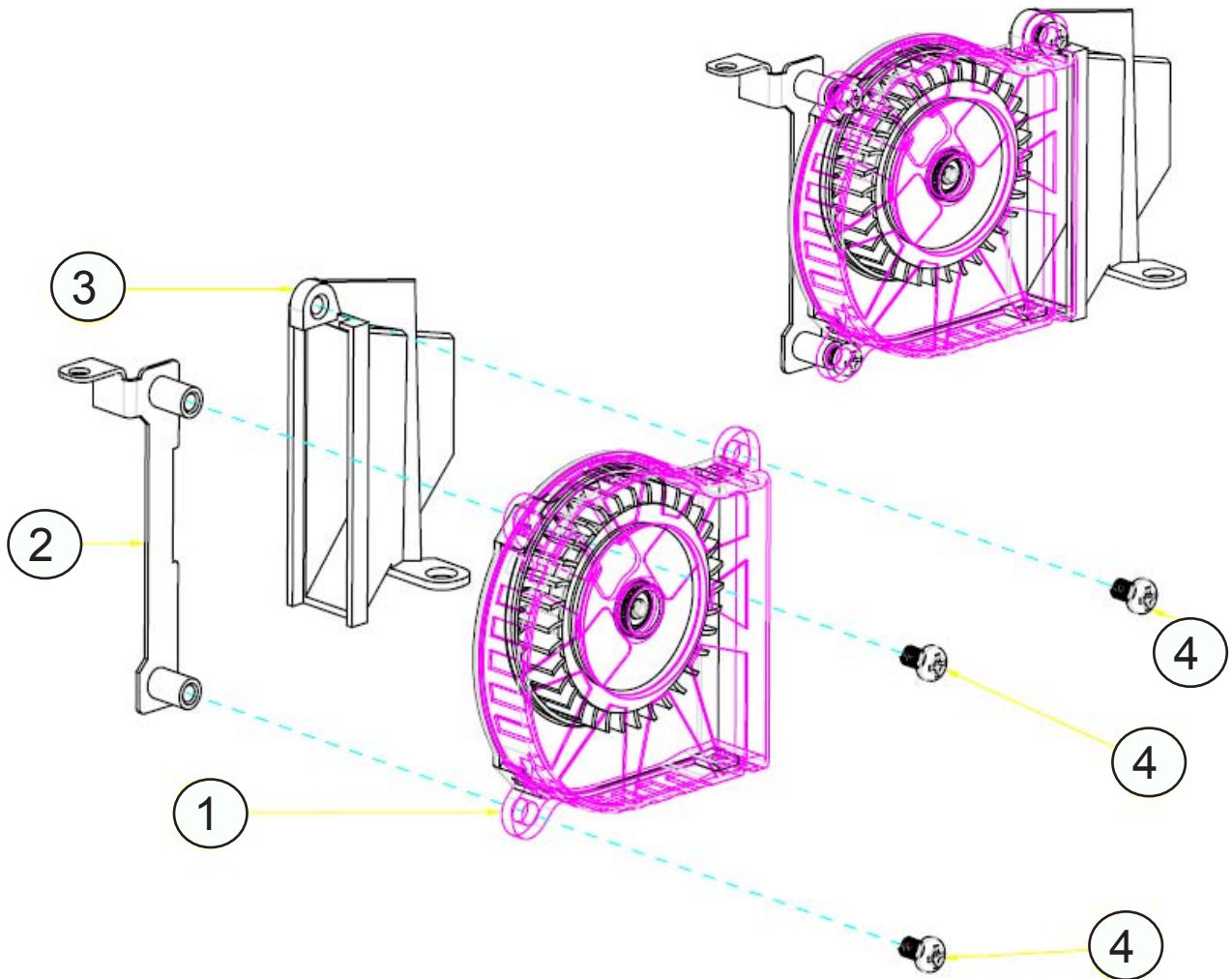

ITEM	P/N	DESCRIPTION	Supply
1	49.89S01G001	LAMP BLOWER / 45*45*10 mm, 60m	
2	61.89S13G001	BLOWER 4510 HOLDER SECC M209X	N
3	61.89S11G001	LAMP BLOWER 4510 DUCT AL M209X	N
4	85.1A126G040	SCREW PAN MECH M2.6*4 Ni	N

ASSY TOP COVER MODULE P3250

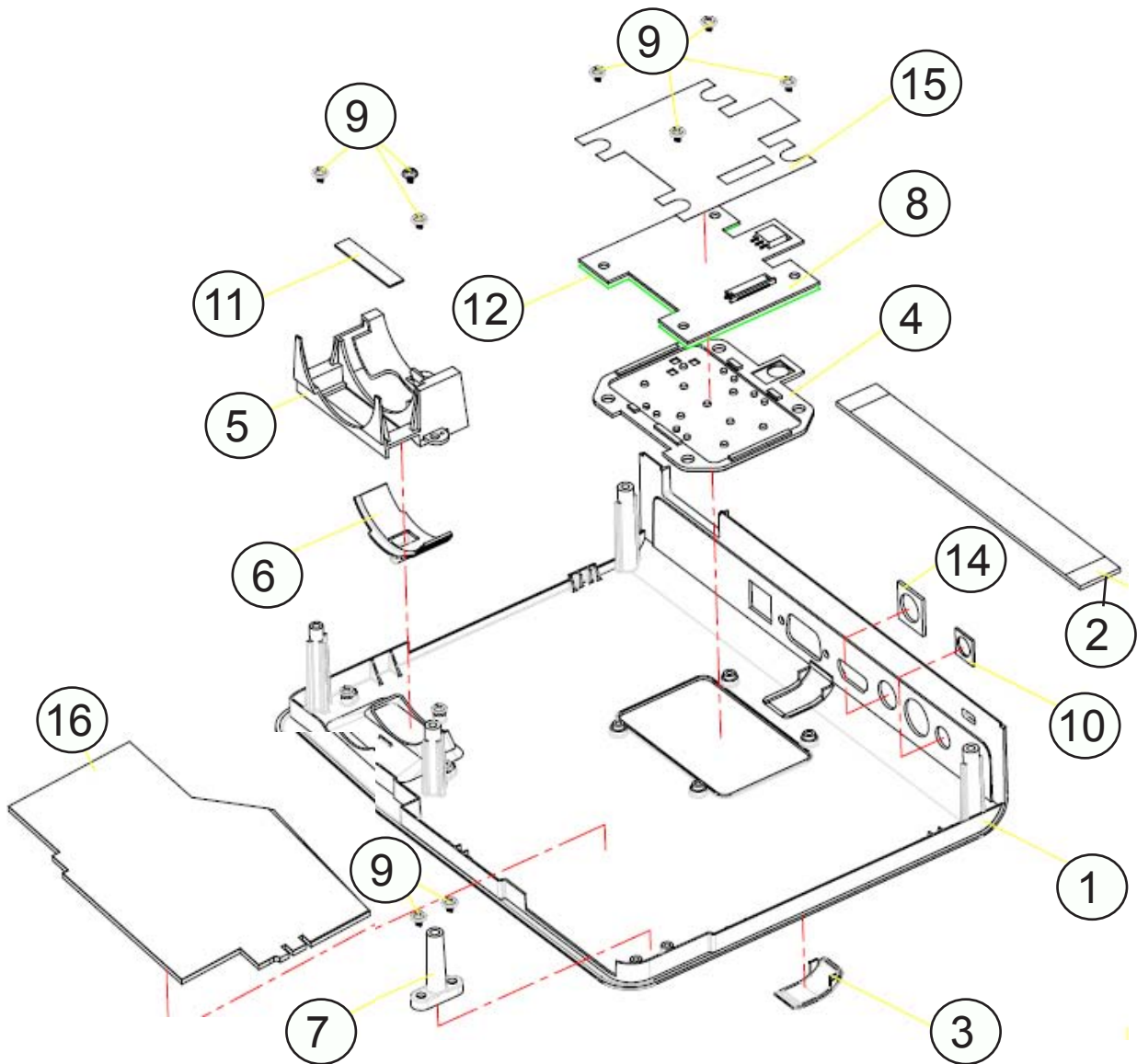

ITEM	P/N	DESCRIPTION	Supply
	70.89Y30GR01	ASSY TOP COVER MODULE FOR P3250(SERVICE)	
1	61.89Y02G001	TOP COVER P3150	N
2	42.89501G002	CABLE FPC 24P P=0.5 150mm KE	
3	51.89Y04G001	TOP IR LENS P3150	N
4	51.89Y11G002	KEYPAD BUTTON P+R P3150	
5	51.89Y06G001	ZOOM RING HOLDER P3150	N
6	51.89Y07G002	ZOOM RING P3150	
7	51.89Y12G001	TOP COVER PILLAR P3150	N
8	80.89Y03G001	PCBA KEYPAD BD FOR P3150	
9	85.1D122G030	SCREW PAN MECH M2*3 Ni(W/WSHER	N
10	41.87W02G001	EMI I/O GASKET (S-VIDEO /RS232	N
11	41.89Y02G001	EMI GASKET W8*H1*L30	N
12	51.89Y13G001	METAL DOME P3150	N
13	41.87W02G001	EMI I/O GASKET (S-VIDEO /RS232	N
14	41.83M11G001	S-VIDEO GASKET 2400MP	N
15	51.89Y15G001	KEYPAD TAPE P3150	N
16	52.89Y06G001	FRAME AL FOIL/F12 LAMP P3150	N

ASSY FRONT COVER P3250

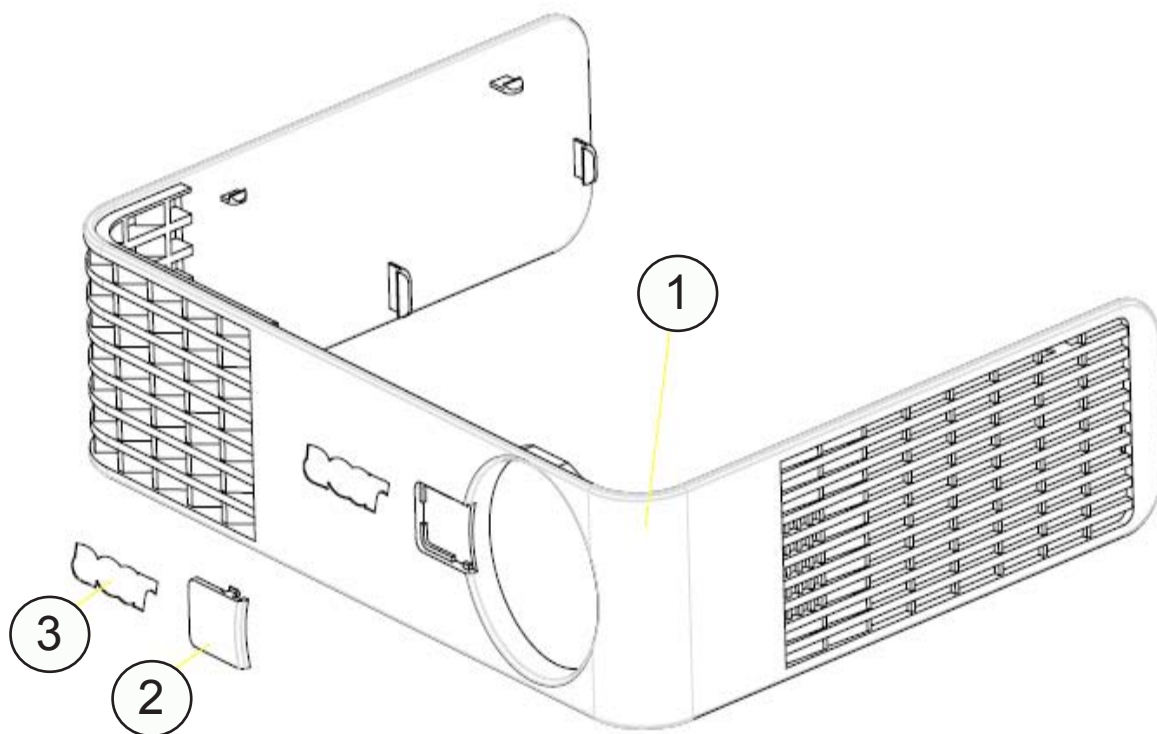

ITEM	P/N	DESCRIPTION	Supply
	70.89Y24GR01	ASSY FRONT COVER MODULE FOR P3150/P3250(SERVICE)	
1	51.89Y01G001	FRONT COVER P3150	N
2	51.89Y03G001	FRONT IR LENS P3150	N
3	61.88T15G001	ACER LOGO FOR X1160	N

ASSY BOTTOM COVER P3250

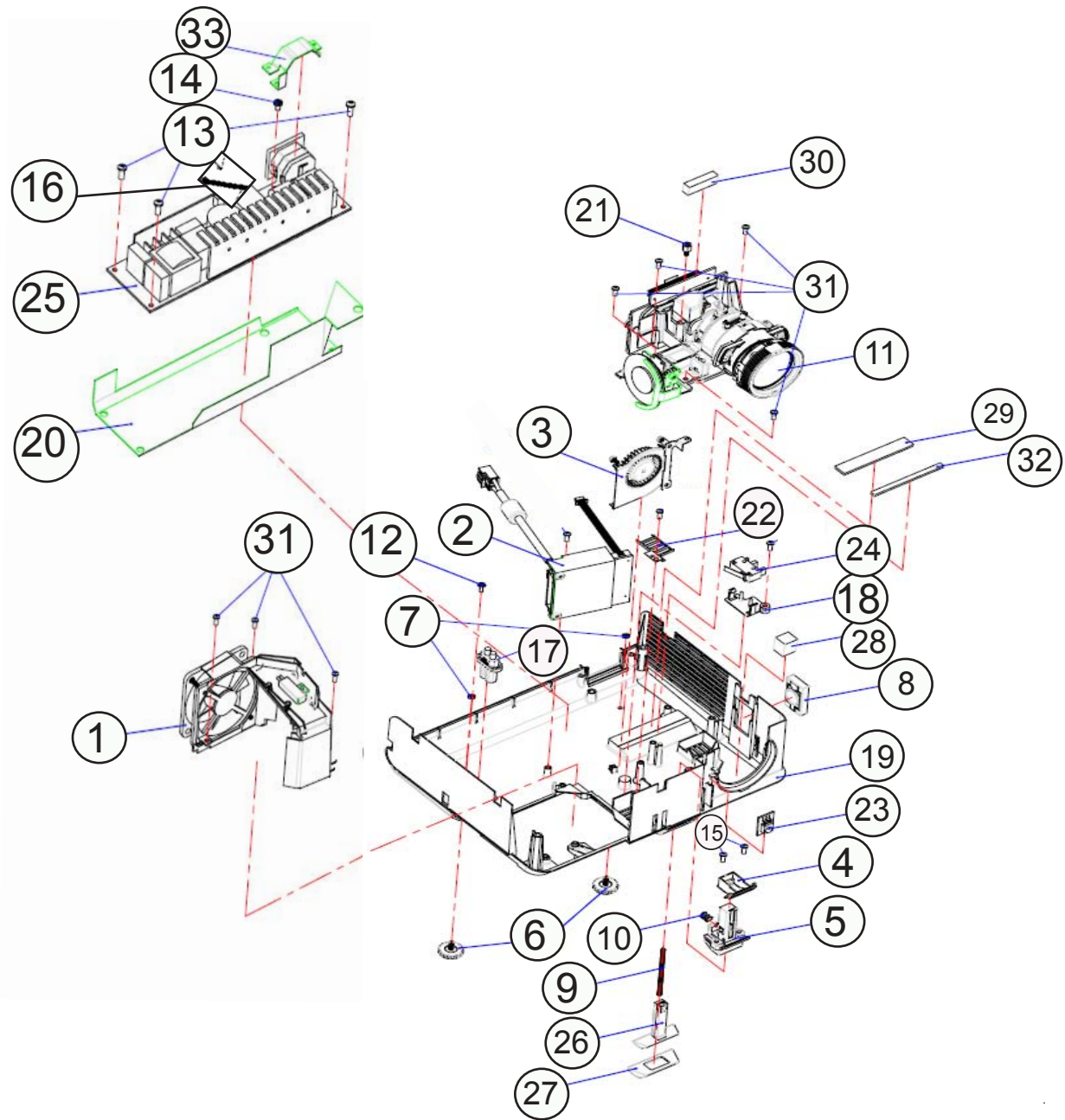

ITEM	P/N	DESCRIPTION	Supply
1	70.89Y17G001	ASSY LAMP HOUSING MODULE M209X	N
2	70.89Y13G001	ASSY DC-DC MODULE P3150	N
3	70.89S09G001	ASSY BLOWER 4510 MODULE M209X	N
4	51.89Y08G001	ELEVATOR PUSH BUTTON P3150	
5	51.89Y09G001	ELEVATOR BASE P3150	N
6	52.89Y02G001	ADJUST FOOT P3150	N
7	86.00122G015	NUT HEX M2.0*0.4P L15 Ni	N
8	70.89Y06G001	ASSY SPEAKER MODULE P3150	N
9	61.89S20G001	ELEVATOR BASE SPRING M209X	N
10	61.89S21G001	ELEVATOR PUSH SPRING M209X	N
11	70.89Y04G001	ASSY OPTICAL ENGINE MODULE P31	N
12	85.1D122G030	SCREW PAN MECH M2*3 Ni(W/WSHER	N
13	85.1A123G060	SCREW PAN MECH M3*6 NI	N
14	85.1C224G051	SCREW PAN MECH M4*5 COLOR W/TO	N
15	85.1A126G040	SCREW PAN MECH M2.6*4 Ni	N
16	42.00472G001	W.A. 5P #28 140MM MAIN BOARD/B	
17	42.00491G001	W.A.2P#22 FEMALE 6KV 150 75	N
18	51.89S18G001	INTERLOCK SWITCH HOLDER PC M20	N
	70.89Y26GR01	ASSY BOTTOM COVER MODULE FOR P3150/P3250 (SERVICE)	
19	61.89Y01G001	BASE COVER P3150	N
20	51.89Y14G001	BALLAST MYLAR P3150	N
21	61.89S24G001	MAIN BOARD STAND-OFF M2.6X4.0m	N
22	61.89S25G001	COLOR WHEEL VENT SUS304 M209X	N
23	80.89S05G001	PCBA IR SENSOR BD FOR M209X	
24	75.89S06G002	NEW BUY ASSY INTERLOCK SWITCH	
25	70.89Y27GR01	ASSY OSRAM BALLAST FOR P3150/P3250 (SERVICE)	
26	51.89Y10G001	ELEVATOR SUPPORT P3150	N
27	52.89Y03G002	ELEVATOR FOOT P3150	
28	41.89S01G001	EMI GASKET W10*H13*L12	N
29	41.89Y01G001	EMI GASKET W10*H3*L55	N
30	41.89S05G001	EMI GASKET W6.5*H12*L30	N
31	85.1A326G060	SCREW PAN HEAD MECH M2.6*6 BLA	N
32	52.89Y05G001	DMD BOTTOM-SIDE THERMAL PAD GR	N
33	61.89Y03G001	AC INLET BRACKET P3150	N

ASSY MAIN BOARD MODULE P3250

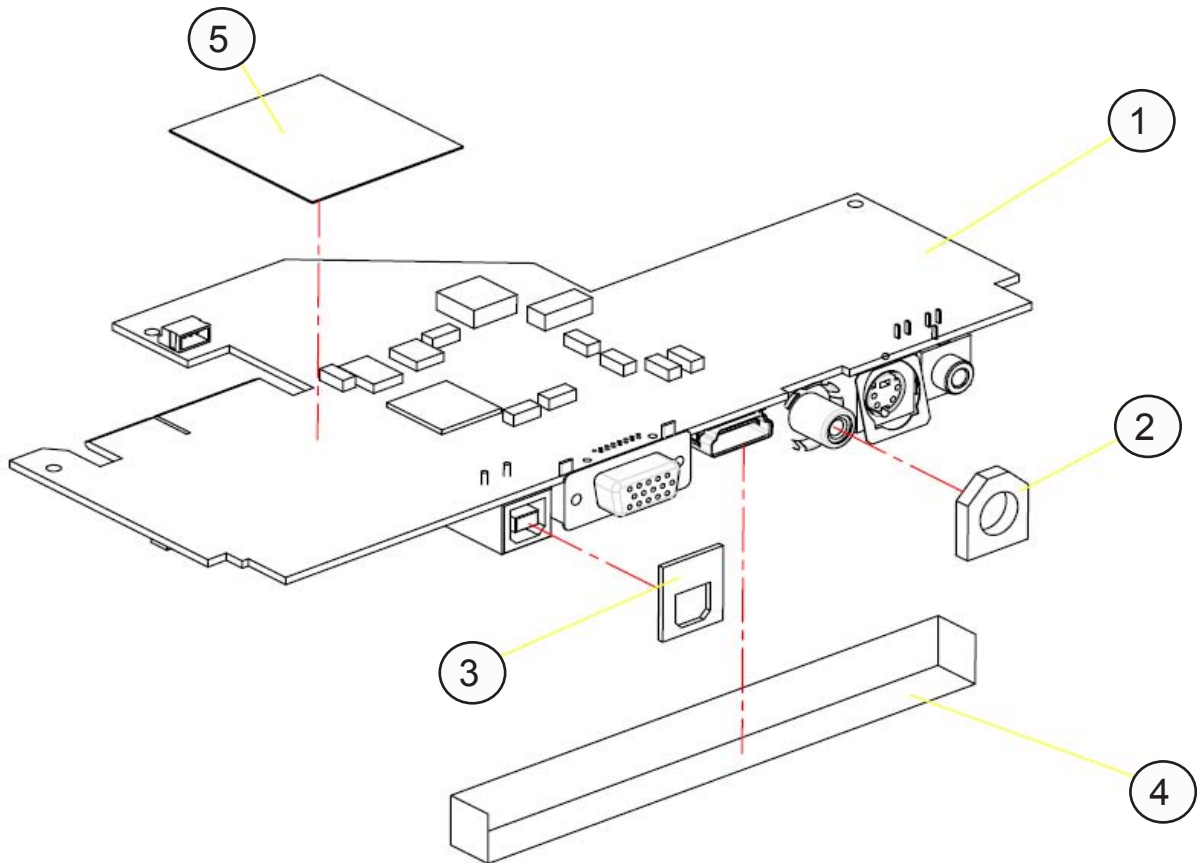

ITEM	P/N	DESCRIPTION	Supply
	70.89Y29GR01	ASSY PCBA MAIN BD MODULE FOR P3250(SERVICE)	
1	80.89Y01G001	PCBA MAIN BOARD FOR P3150	N
2	41.82B17G001	EMI VIDEO GASKET	N
3	41.82G03G001	EMI GASKET USB CONNECTOR EP719	N
4	41.89S14G001	EMI TAPE W30*L30	N
5	51.89Y17G001	MAIN BOARD LIGHTCUT MYLAR P315	N

ASSY DC-DC MODULE P3250

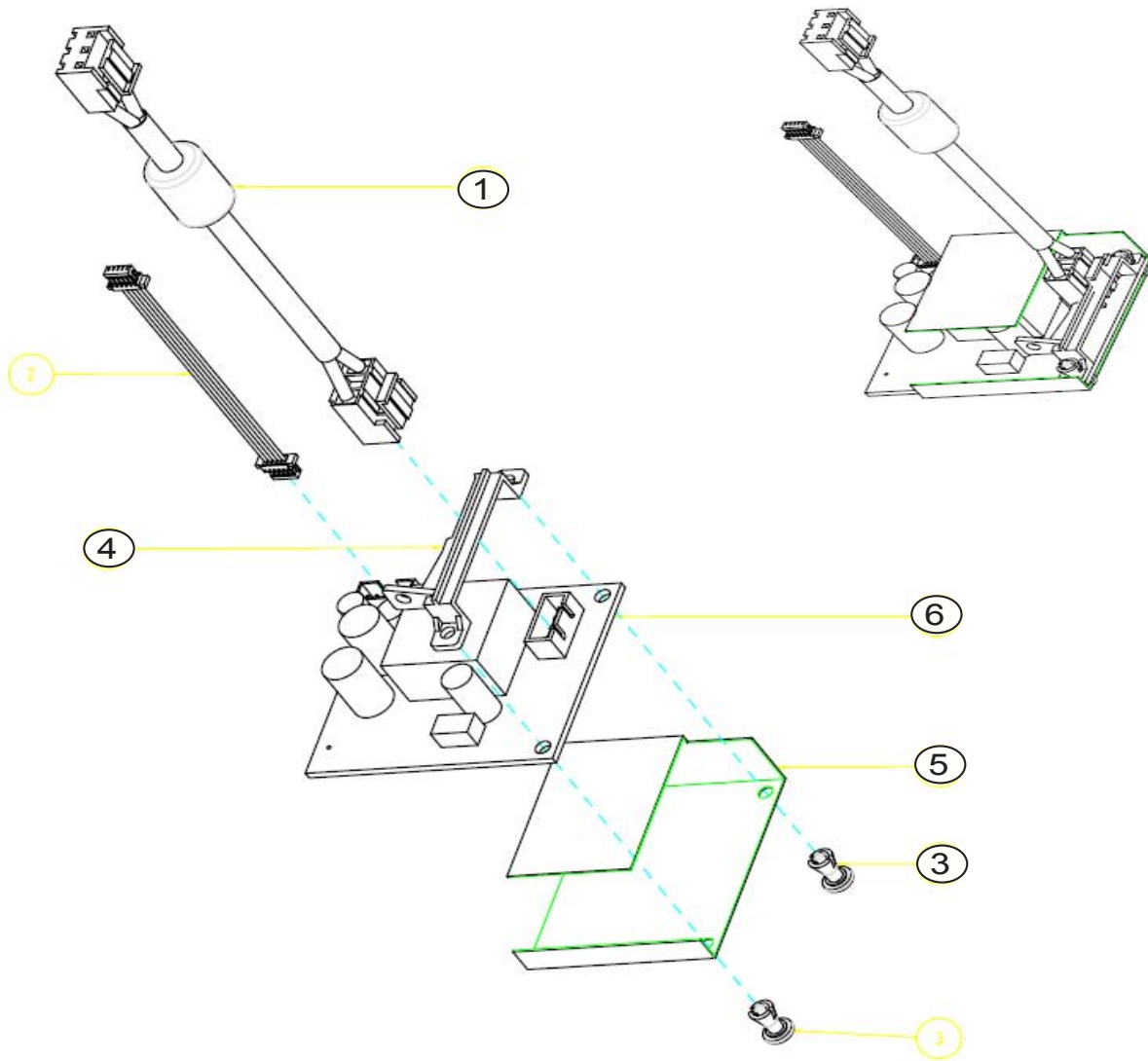

ITEM	P/N	DECRPTION	Supply
	70.89Y28GR01	ASSY DC-DC MODULE FOR P3150/P3250 (SERVICE)	
1	42.004A1G001	W.A.4P #24/#26 100mm DC.DC/BALLAST	
2	42.004B1G001	W.A. 5P #26 140mm DC-DC/MAIN BOARD M209X	
3	51.00061G001	PLASTIC RIVET E3.0 SR-3L"A0"	N
4	51.89S17G001	DC HOLDER PC M209X	N
5	51.89S23G001	DC-DC MYLAR M209X	N
6	75.89S08G001	ASSY MATRITEK D2D M209P	N

ASSY LAMP HOUSING MODULE P3250

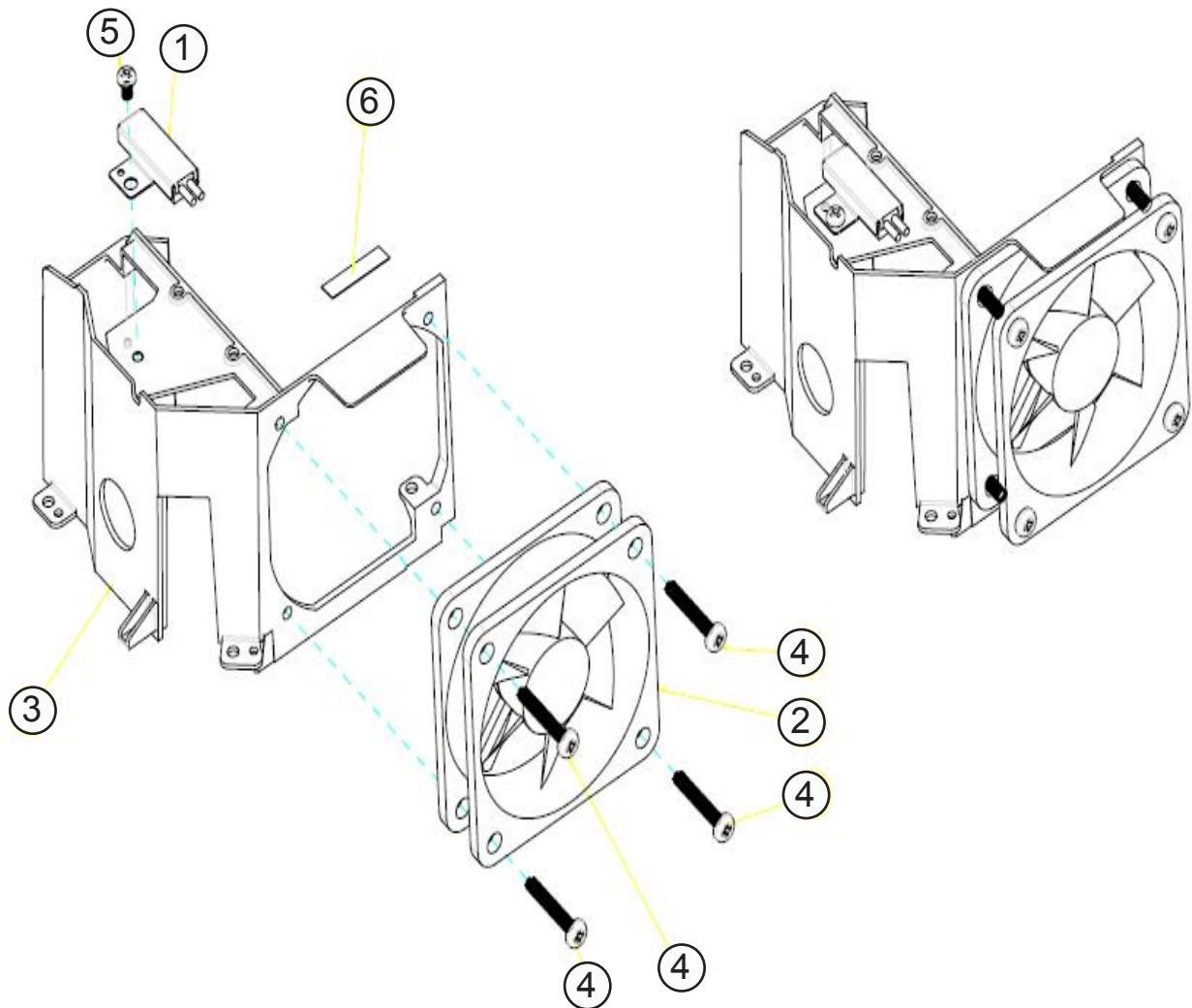

ITEM	P/N	DECRPTION	Supply
1	43.89S01G001	TH-RMAI SWITCH WITH BRACKET (KLIX-ON YSII)	
2	49.85M03G001	SYSTEM FAN/55*55*15mm	
3	61.89Z06G001	LAMP HOUSING MG ALLOY EX330	N
4	85.1A123G180	SCREW PAN MECH M3*18 NI EP910	N
5	85.1A126G040	SCREW PAN MECH M2.6*4 Ni	N
6	41.89S03G001	EMI TAPE W5*L25 H0.65	N

ASSY SPEAKER MODULE P3250

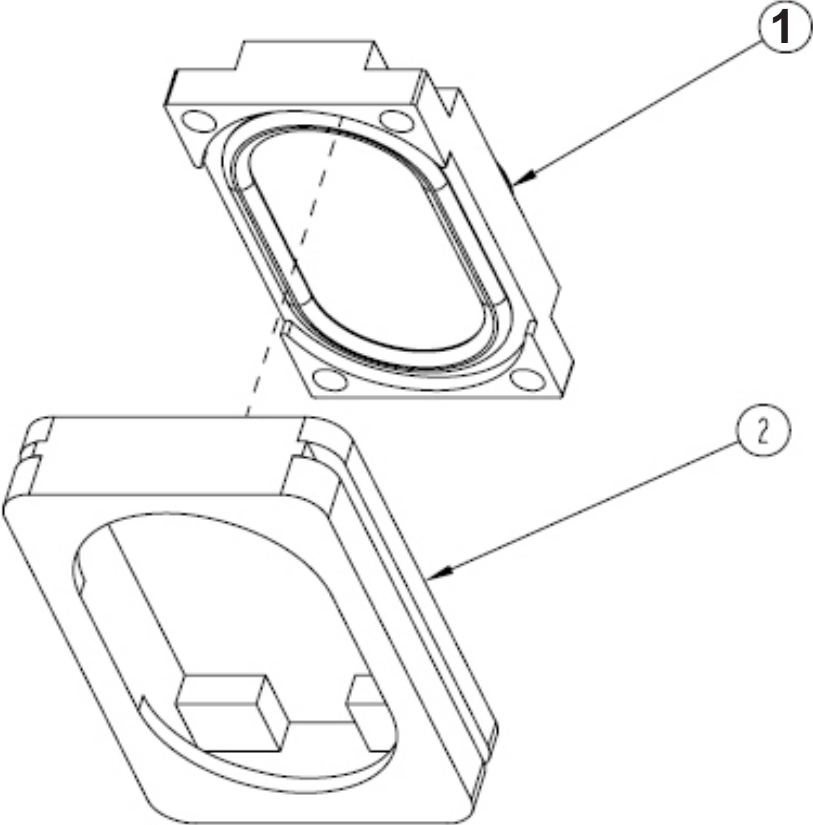

ITEM	P/N	DECRPTION	Supply
1	49.89Y01G001	SPEAKER MINI IW 4 ohm 140 mm P3150	
2	52.89Y01G001	SPEAKER RUBBER P3150	N

ASSY ENGINE MODULE P3250

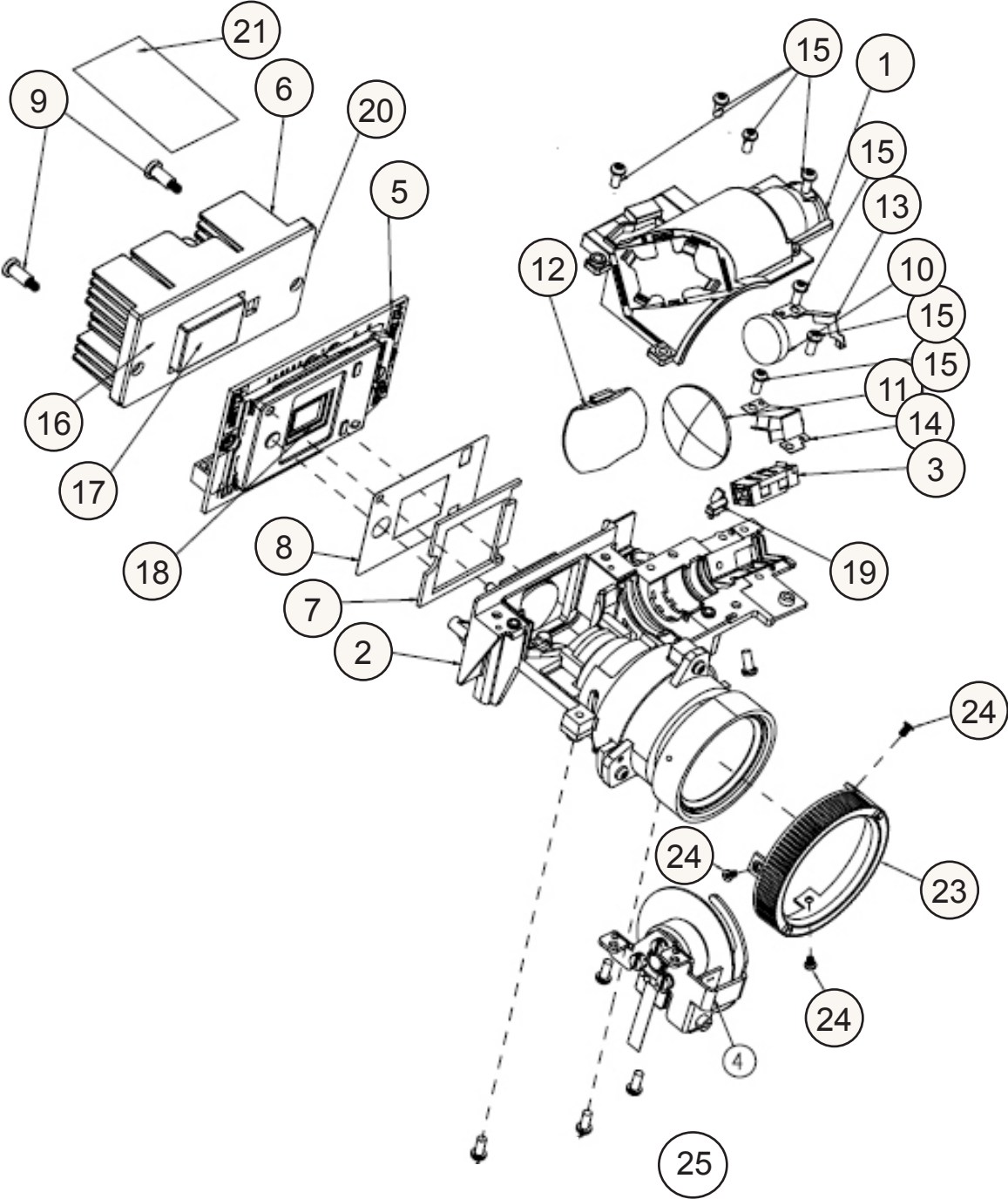

ITEM	P/N	DESCRIPTION	Supply
	70.89Y22GR01	ASSY ENGINE MODULE FOR P3150/ P3250(SERVICE)	
1	70.89Y15G001	ASSY ENGINE BOTTOM COVER P3150	N
2	70.89Y05G001	ASSY ENGINE BASE MODULE P3150	N
3	70.89Y16G001	ASSY ROD MODULE P3150	N
4	70.89Y21GR01	ASSY COLOR WHEEL MODULE P3150	
5	80.89S02G001	PCBA DMD BOARD FOR M209X	
6	61.89S10G001	DMD HEATSINK AL M209X	N
7	52.88N04G002	DMD RUBBER NEW 1.3T X15	N
8	61.88N15G001	DMD MASK,SUS301,X15	N
9	85.4A826G118	STEP SCREW FOR TYPEX DMD M2.6*11.8mm,X15	
10	23.88N20G001	YO CONDENSER1 FOR X15	N
11	23.88N20G011	YO CONDENSER2 FOR X15	N
12	23.88N06G011	YO PLASTIC RELAY FOR X15	N
13	61.88N13G002	ROD COVER NEW,SUS301,X15	N
14	61.88N12G001	ROD SPRING,SUS301,X15	N
15	85.1A526G060	SCREW PAN MECH M2.6*6 NI NYLOK	N
16	52.88N03G002	HEAT SINK RUBBER(X15) X1160	N
17	52.87J01G001	DMD THERMAL PAD 25*17*0.5t FUJIPOLY SAR- GON GR-Hn	
18	48.87M01G001	DMD Type-X 1024x768 PIXEL 0.55" XGA LVDS	
19	61.88N39G001	STOP MASK MG X15	N
20	61.89Y06G001	HEX SCREW M2.6*H6.8*L5, STEEL	N
21	41.82K09G001	EMI TAPE 30*50mm	N
22	85.0A126G040	SCREW DOUBLE FLAT MECH M2.6*4Ni	N
23	51.89Y05G001	FOCUS RING P3150	
24	85.WA321G040	SCREW PAN TAP M1.7*4 BLACK	N
25	80.88N04G001	PCBA PHOTO SENSOR BOARD FOR EP721	

AK. P3250

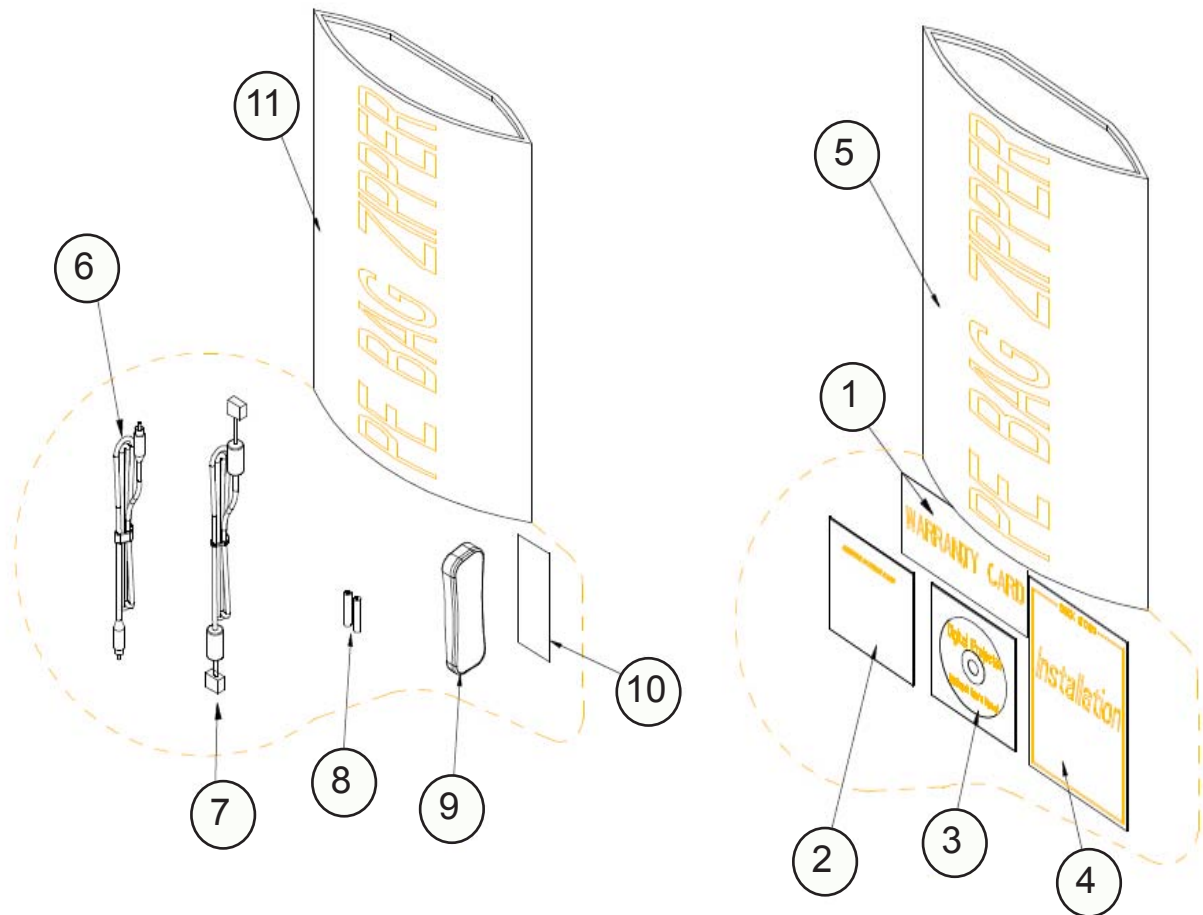

ITEM	P/N	DESCRIPTION	Supply
1	36.00006G031	WARRANTY CARD ,EUROPE FOR ACER	N
2	36.00027G001	SERVICE STATION CARD	N
3	36.89Y01G001	USER'S GUIDE MULTILINGUAL (C	N
4	36.89Y02G001	QUICK START CARD MULTILINGUA	N
5	51.86213G002	PE BAG ZIPPER #9 W/RECYCLING M	N
6	42.00232G001	CABLE COMPOSITE VIDEO 2M YELLO	N
7	42.83M09G101	CABLE MINI JACK TO MINI JACK	N
8	46.82V02G001	BATTERY #4 1.5V R04 PD120	N
9	45.87U01G106	INFRARED REMOTE CONTROLLER L	
10	36.00029G001	SECURITY CARD FOR ACER	N
11	51.86213G002	PE BAG ZIPPER #9 W/RECYCLING M	N

DP. P3250

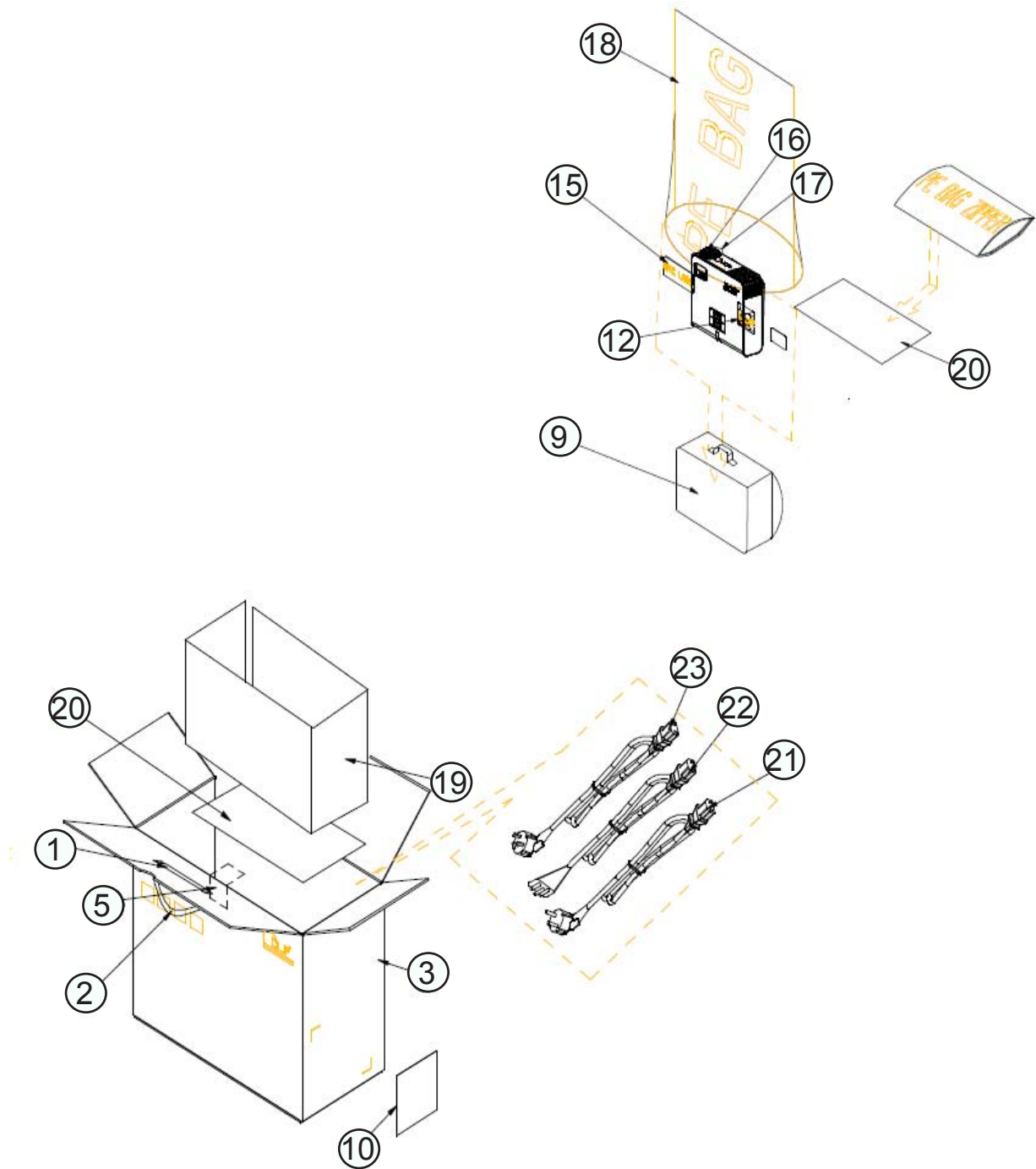

ITEM	P/N	DESCRIPTION	Supply
1	51.00201G001	HANDLE BAR 1.PE HD70	N
2	51.00200G001	HANDLE BAR 2. PE HD70	N
3	55.89Y01G001	CARTON CARRY BOX P3150	N
4	55.89Y02G001	CENTER PAPER BOX P3150	N
5	35.82L04G001	ACER TAPE 45M FOR CARTON	N
6	55.87W04G001	CORNER PAPER P5271	N
7	58.86202GC02	COVER PALLET 1150*970mm FOR 34	N
8	58.86201GC02	WOOD PALLET 48"*40*5"(DOUBLE F	N
9	53.89Y01G001	SOFT CARRY BAG P3150	N
10	35.52302G091	LABEL CARTON 108*92 BLANK	N
11	55.87202G001	BOTTOM PAPER COVER PLATE 1230*	N
12	57.00001G001	PACK SIO2 DRIER 20g	N
13	35.82L04G001	LAMP WARNING LABEL ARES A	N
14	35.82V02G001	LABEL CARTON(SEAL) 110*50mm PD	N
15	35.85M02G001	SPEC LABEL PD311	N
16	52.89Y04G002	LENS-CAP FOR P3150	N
17	51.89Y16G001	LENS CAP STRAP P3150	N
18	51.00174G002	PE BAG 380*310*0.07mm FOR OP	N
19	56.89Z01G001	AIR BAG RIM EX330	N
20	56.89Z02G001	AIR BAG TOP/BOTTOM EX330	N
21	42.00120G011	CABLE POWER CORD 1.8M SP-023/IS-14 EUROPE DIS-WARNING LABEL	
22	42.00110G011	CABLE POWER CORD 1.8M SP-60/IS-14 UK DIS-WARNING LABEL	
23	42.00131G011	CABLE POWER CORD 1.8M SP-027/IS-14 SWITZERLAND DIS-WARNING LABEL	

Appendix B

I. Serial Number System Definition

Serial Number Format for Projector(for non-refresh models,take P3150 for example)

EYJ6701W02 811 00000 59 00

① ② ③ ④ ⑤

① : EYJ6701W02 = Part Number excluded “dot”

② : 811 = Week Code(ex:2008 = 8,the eleven weeks of the year = 11)

③ : 00000 = Serial Numbers

④ : 59 = Manufacturing Code

⑤ : 00 = Projector. Version

EX: EYJ6701W02811000005900

This label represents the serial number for P3150. It is produced for Europe at CPC on eleven week of 2008. Its serial code is 00000.

Serial Number Format for Projector(for refresh models,take P3150refresh for example)

EYJ8401006 829 00000 59 0 1

① ② ③ ④ ⑤ ⑥

① : EYJ8401006 = Part Number excluded “dot”

② : 829 = Week Code(ex:2008 = 8 twenty-nine weeks of the year = 29)

③ : 00000 = Serial Numbers

④ : 59 = Manufacturing Code

⑤ : 0 = Projector. Version

⑥ : 1 = Default Language Information

EX: EYJ8401006829000005901

This label represents the serial number for P3150 refresh. It is produced for Europe at CPC on twenty-nine week of 2008. Its serial code is 00000.

Note: About the discrimination between refresh model and non refresh model, please refer to RM-P-A08015.

II. PCBA Code Definition

PCBA Code for Projector

A **B** **XXX** **XXXXXXXXXX** **CC** **XXX** **EEEE**
① ② ③ ④ ⑤ ⑥ ⑦

- ① : ID
- ② : Vendor Code
- ③ : Firmware Version
- ④ : P/N
- ⑤ : MB Version
- ⑥ : Date Code
- ⑦ : S/N